

STUDENT NAME _____

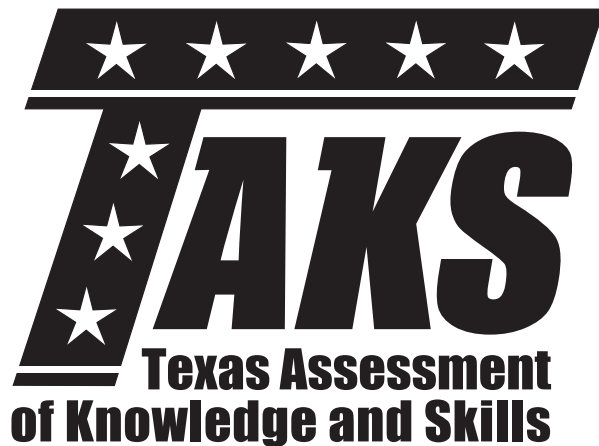

EXIT LEVEL
ENGLISH LANGUAGE ARTS
MATHEMATICS
SCIENCE
SOCIAL STUDIES

Administered July 2006

Mathematics Chart

LENGTH

Metric

1 kilometer = 1000 meters

1 meter = 100 centimeters

1 centimeter = 10 millimeters

Customary

1 mile = 1760 yards

1 mile = 5280 feet

1 yard = 3 feet

1 foot = 12 inches

CAPACITY AND VOLUME

Metric

1 liter = 1000 milliliters

Customary

1 gallon = 4 quarts

1 gallon = 128 ounces

1 quart = 2 pints

1 pint = 2 cups

1 cup = 8 ounces

MASS AND WEIGHT

Metric

1 kilogram = 1000 grams

1 gram = 1000 milligrams

Customary

1 ton = 2000 pounds

1 pound = 16 ounces

TIME

1 year = 365 days

1 year = 12 months

1 year = 52 weeks

1 week = 7 days

1 day = 24 hours

1 hour = 60 minutes

1 minute = 60 seconds

Metric and customary rulers can be found on the separate Mathematics Chart.

Mathematics Chart

Perimeter	rectangle	$P = 2l + 2w$ or $P = 2(l + w)$
Circumference	circle	$C = 2\pi r$ or $C = \pi d$
Area	rectangle	$A = lw$ or $A = bh$
	triangle	$A = \frac{1}{2}bh$ or $A = \frac{bh}{2}$
	trapezoid	$A = \frac{1}{2}(b_1 + b_2)h$ or $A = \frac{(b_1 + b_2)h}{2}$
	circle	$A = \pi r^2$
Surface Area	cube	$S = 6s^2$
	cylinder (lateral)	$S = 2\pi rh$
	cylinder (total)	$S = 2\pi rh + 2\pi r^2$ or $S = 2\pi r(h + r)$
	cone (lateral)	$S = \pi rl$
	cone (total)	$S = \pi rl + \pi r^2$ or $S = \pi r(l + r)$
	sphere	$S = 4\pi r^2$
Volume	prism or cylinder	$V = Bh^*$
	pyramid or cone	$V = \frac{1}{3}Bh^*$
	sphere	$V = \frac{4}{3}\pi r^3$
<i>*B represents the area of the Base of a solid figure.</i>		
Pi	π	$\pi \approx 3.14$ or $\pi \approx \frac{22}{7}$
Pythagorean Theorem		$a^2 + b^2 = c^2$
Distance Formula		$d = \sqrt{(x_2 - x_1)^2 + (y_2 - y_1)^2}$
Slope of a Line		$m = \frac{y_2 - y_1}{x_2 - x_1}$
Midpoint Formula		$M = \left(\frac{x_1 + x_2}{2}, \frac{y_1 + y_2}{2} \right)$
Quadratic Formula		$x = \frac{-b \pm \sqrt{b^2 - 4ac}}{2a}$
Slope-Intercept Form of an Equation		$y = mx + b$
Point-Slope Form of an Equation		$y - y_1 = m(x - x_1)$
Standard Form of an Equation		$Ax + By = C$
Simple Interest Formula		$I = prt$

DIRECTIONS

Read each question. Then fill in the correct answer on your answer document. If a correct answer is not here, mark the letter for “Not here.”

SAMPLE A

Find the slope of the line $2y = 8x - 3$.

A $-\frac{3}{2}$

B 4

C 8

D Not here

SAMPLE B

Janice uses a rectangular box to store her art supplies. The dimensions of the rectangular box are 22.5 inches by 14 inches by 11.5 inches. What is the volume of this box in cubic inches?

Record your answer and fill in the bubbles on your answer document. Be sure to use the correct place value.



- 1 The graph of the equation $y = 0.4x^2 - 2$ is shown below.

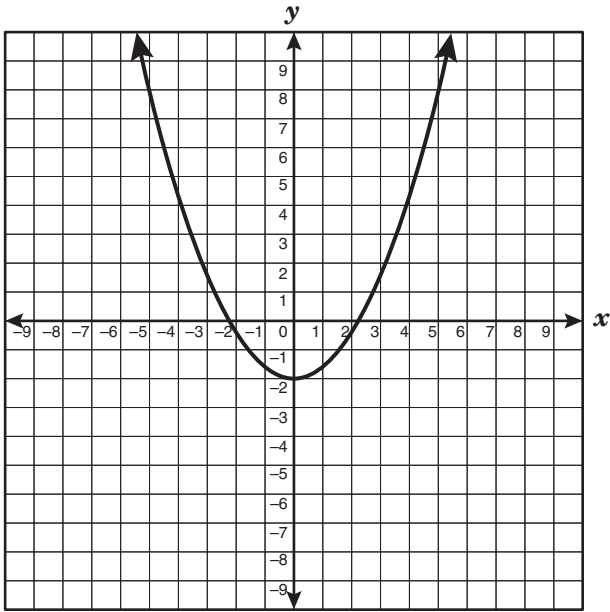

If the graph is translated 3 units up, what will be the equation of the resulting graph?

- A $y = 0.4x^2 + 1$
- B $y = 0.7x^2 - 2$
- C $y = 0.4x^2 + 5$
- D $y = 3.4x^2 - 2$

- 2 A basketball player made 12 free throws in his last 36 attempts. How many free throws would the basketball player be expected to make in 78 attempts?

- F 20
- G 26
- H 52
- J 234

- 3 George saves 15% of his total gross weekly earnings from his 2 part-time jobs. He earns \$6.15 per hour from one part-time job and \$7.25 per hour from the other part-time job. George works a total of 40 hours between the two jobs each week. What additional information is needed to determine the amount of his earnings he saves each week?

- A The number of days he works at each job
- B The number of hours he works at each job
- C The number of hours he works each day
- D The number of hours he works each month

4 Which net best represents the hexagonal prism shown below?

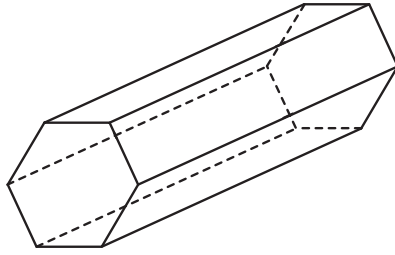

F



H

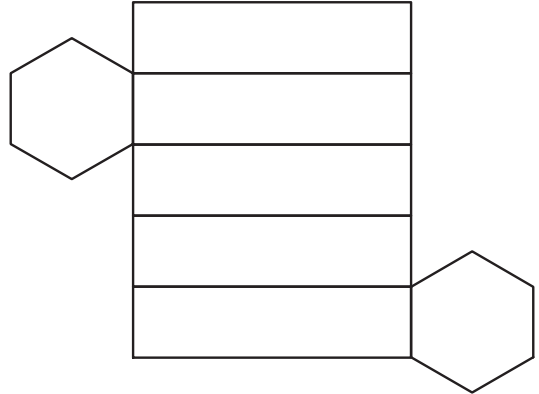

G

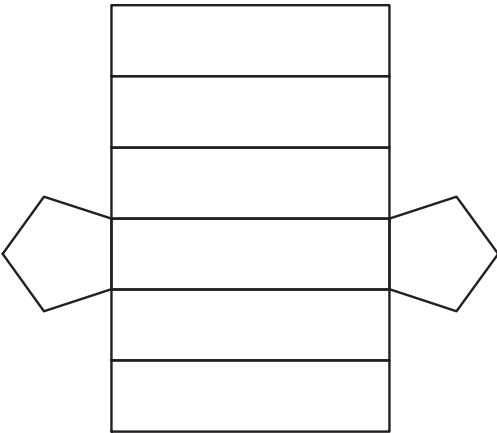

J

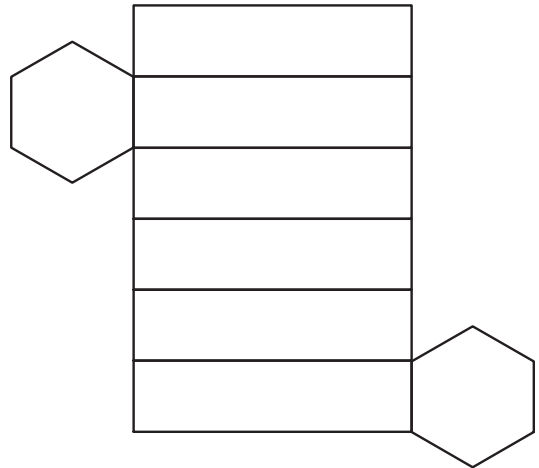

- 5 A function is described by the equation $y = 2x^2 - 5x - 3$, in which y is dependent on x . If a value for the independent variable is selected from the set $\{-4, -1, 0, 2, 5\}$, which of the following is a corresponding dependent value?
- A 9
 B -6
 C -5
 D 0

- 6 The drama department at McHenry High School has built a stage floor in the shape of a regular octagon. The length of each side of the octagon is 4 yards.

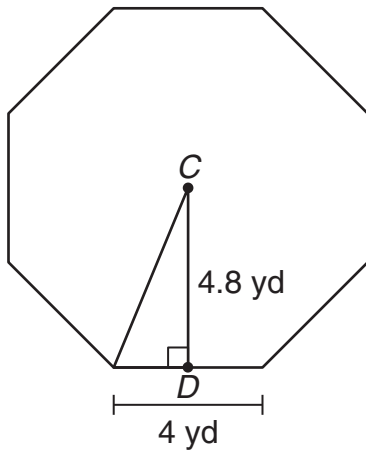

\overline{CD} is the apothem. What is the approximate area of the stage floor?

$$[\text{Area} = \frac{1}{2}(\text{apothem})(\text{perimeter})]$$

- F 57.9 yd^2
 G 76.8 yd^2
 H 115.9 yd^2
 J 154.5 yd^2

- 7 The graph shows quadrilateral $TUVW$, \overline{KN} , and \overline{KL} .

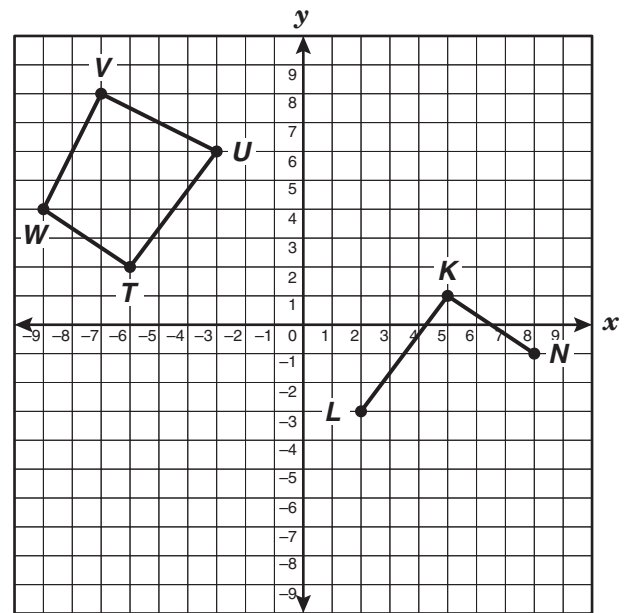

At what coordinate point should vertex M be placed to make quadrilateral $KLMN$ congruent to quadrilateral $TUVW$?

- A $(6, -4)$
 B $(4, -5)$
 C $(5, -5)$
 D $(6, -5)$

8 The graph below shows the relationship between temperature and the density of water.

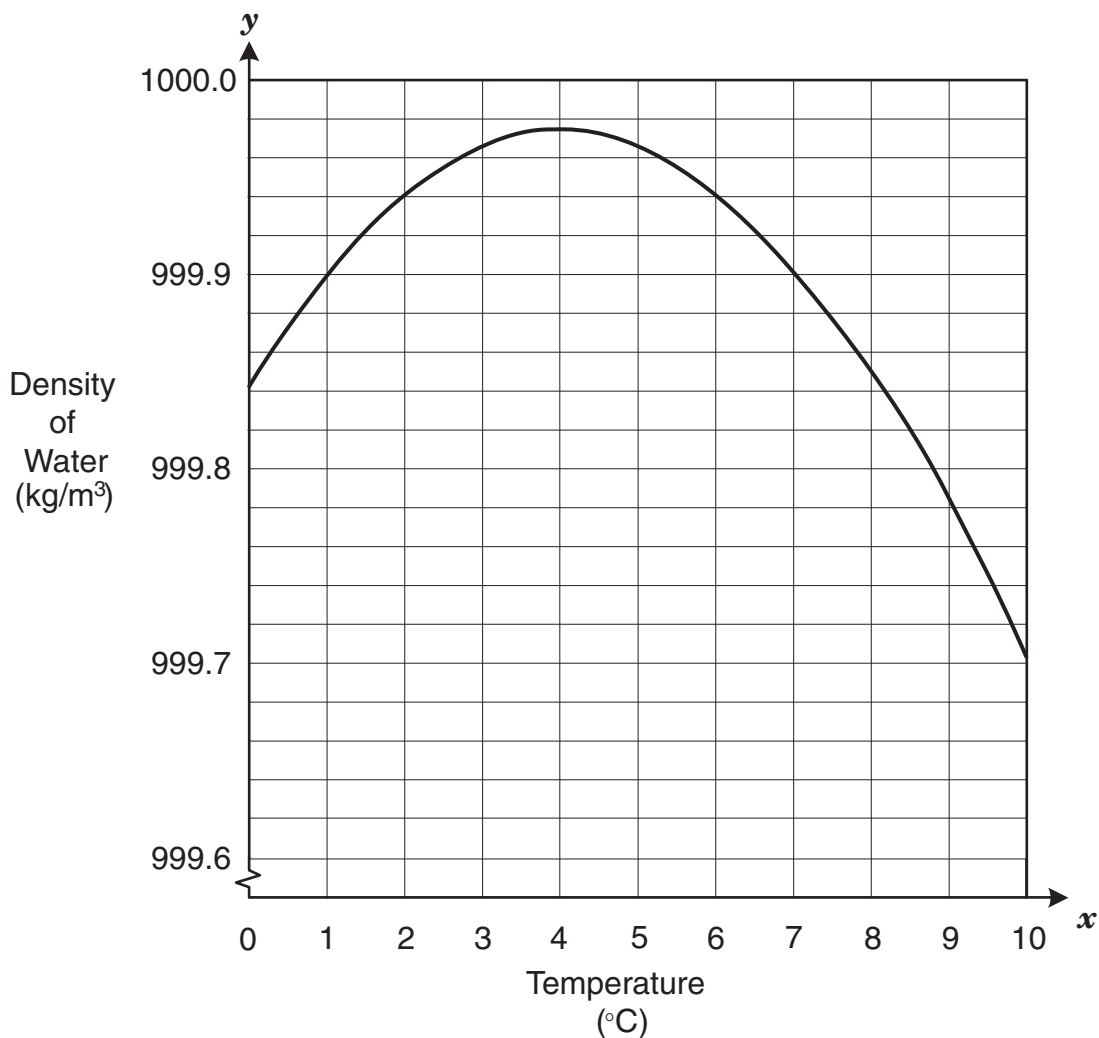

Which of the following statements best describes this relationship?

- F** The density of water increases as temperature increases between 4°C and 10°C.
- G** The density of water decreases as temperature increases between 0°C and 4°C.
- H** The density of water decreases as temperature increases between 4°C and 10°C.
- J** The density of water remains constant as temperature increases.

9 An investor has a total of 45 one-ounce ingots, made of either gold or silver, worth \$7636.50. The value of a gold ingot is \$280.00, and the value of a silver ingot is \$4.25. Which system of equations can be used to find g , the number of gold ingots, and s , the number of silver ingots?

A $g - s = 45$

$$280.00g + 4.25s = 7636.50$$

B $g + s = 45$

$$280.00g + 4.25s = 7636.50$$

C $g + s = 45$

$$4.25g + 280.00s = 7636.50$$

D $g - s = 7636.50$

$$280.00g + 4.25s = 45$$

10 If $XY = 8$ feet and $XZ = 17$ feet, what is the area of $\triangle XYZ$?

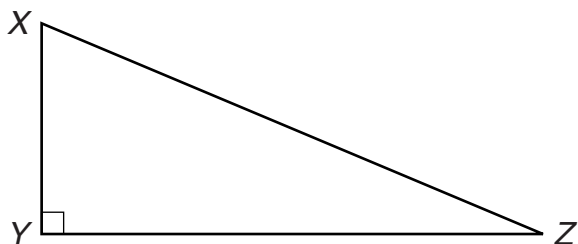

F 15 ft^2

G 30 ft^2

H 60 ft^2

J 120 ft^2

11 What is the approximate distance between points $(-7, 2)$ and $(11, -5)$?

A 18.36 units

B 19.31 units

C 18.25 units

D 8.06 units

- 12 The graphs below represent functions of the form $y = ax^2$. In which of the following graphs does a have the smallest value?

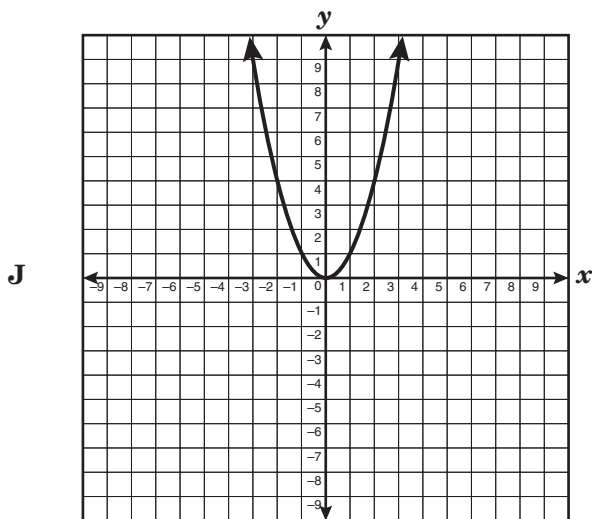
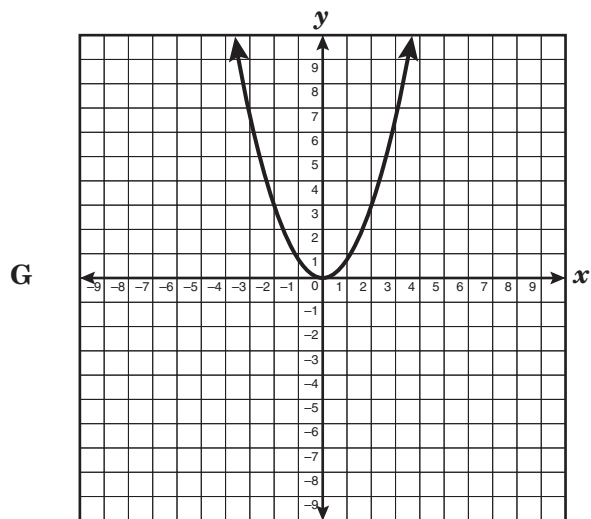
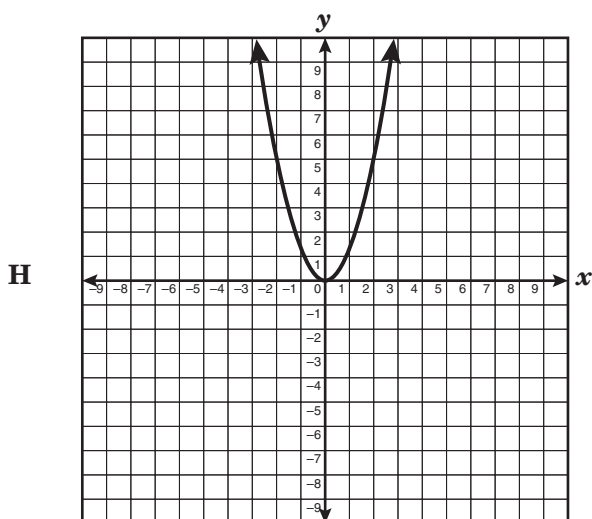
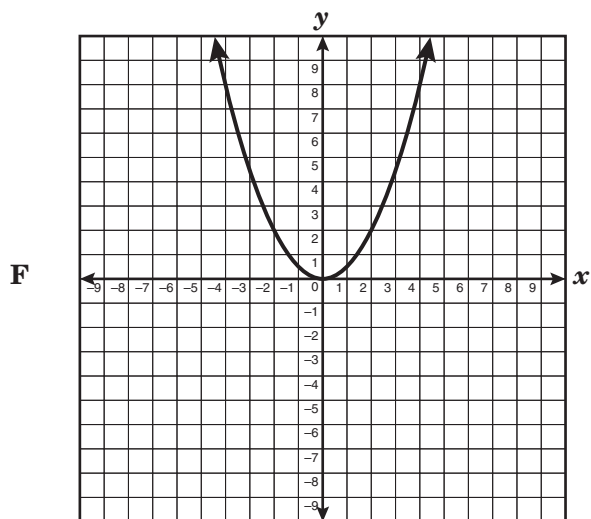

- 13 Line a intersects line b and line c , as shown below.

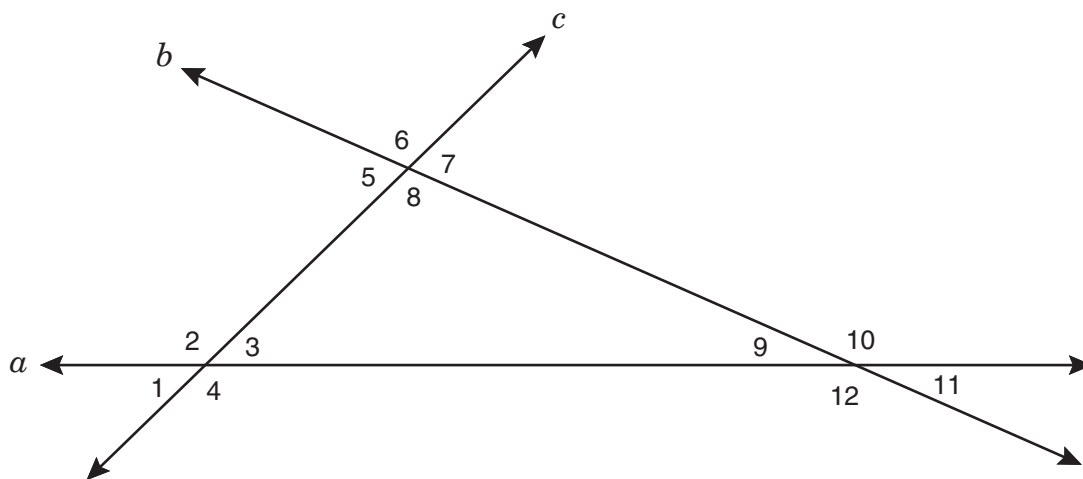

Which of the following angle relationships must be true?

- A $m\angle 2 + m\angle 6 + m\angle 10 = 180^\circ$
B $m\angle 3 + m\angle 6 + m\angle 12 = 180^\circ$
C $m\angle 1 + m\angle 6 + m\angle 11 = 180^\circ$
D $m\angle 4 + m\angle 6 + m\angle 9 = 180^\circ$
-
- 14 The initial pressure inside a closed container is 200 pounds per square inch (psi). As the temperature inside the container increases, the pressure increases. If the pressure increases 7.5 psi for each degree Fahrenheit of increased temperature, which equation best represents p , the pressure inside the container after the temperature has increased t degrees?
- F $p = 7.5t$
G $p = 200 + 7.5t$
H $p = 200t + 7.5$
J $p = 200t + 7.5t$

15 What is the apparent slope of the line graphed below?

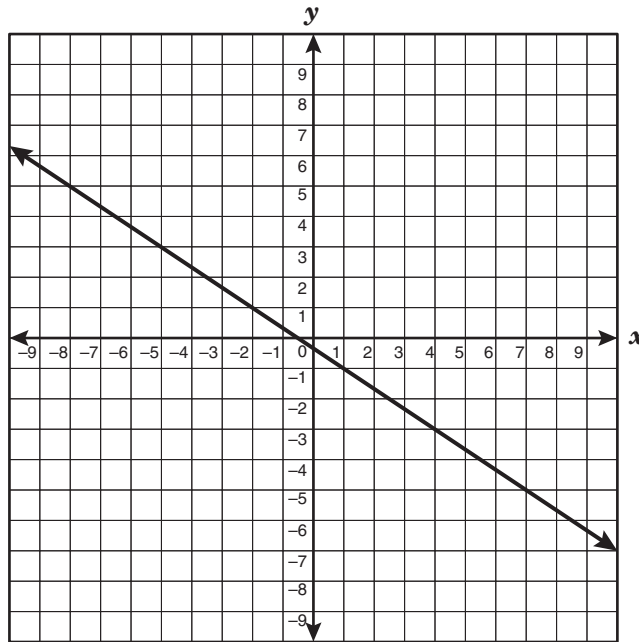

- A $-\frac{3}{2}$
- B $\frac{2}{3}$
- C $\frac{3}{2}$
- D $-\frac{2}{3}$

- 16 A total of 550 students from the Fairfield High School junior class voted on their choice for their senior class gift to the school. The table below shows the results of the vote.

Senior Class Gift

Type	Number of Votes
Mural	220
Statue	88
Garden	77
Scholarships	121
Other	44

Which graph best represents the results of the survey?

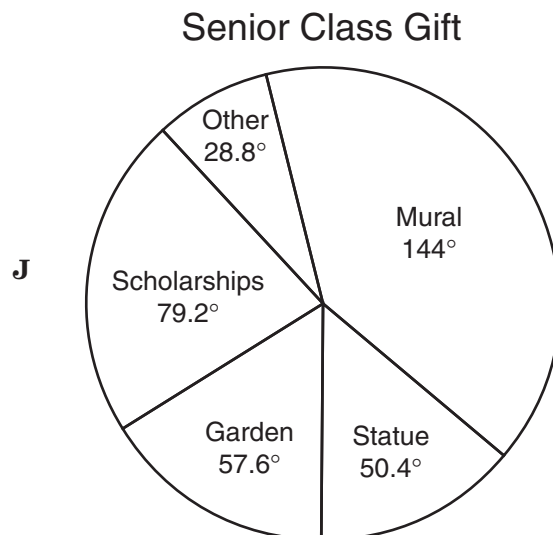
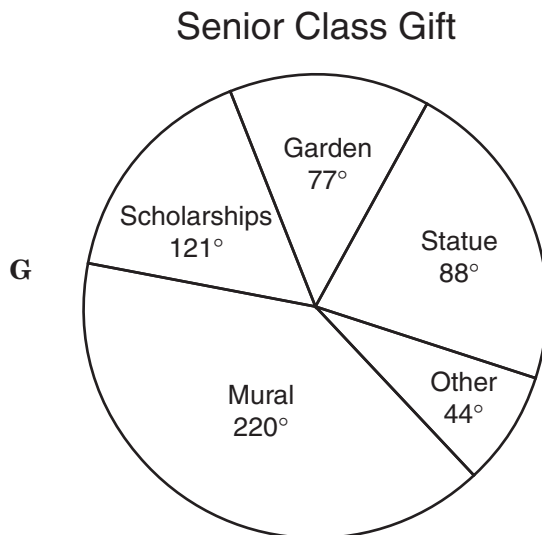
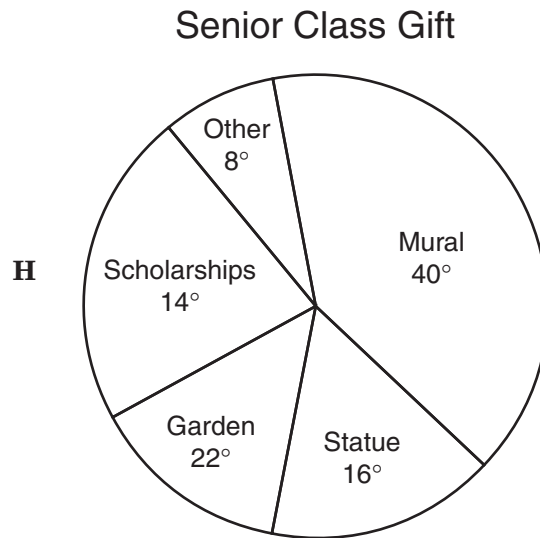
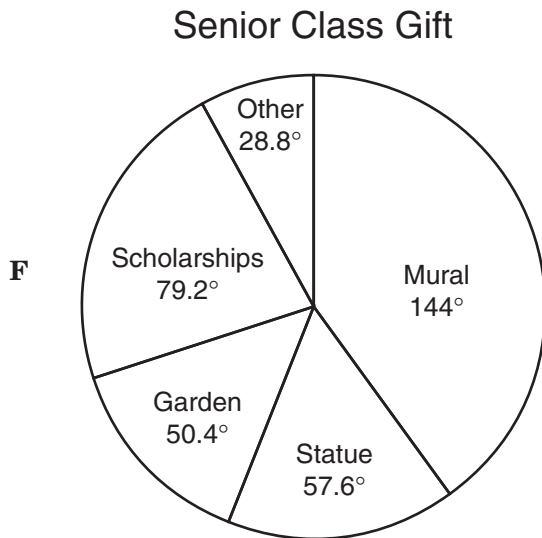

- 17 Which quadratic equation best represents the parabola shown below?

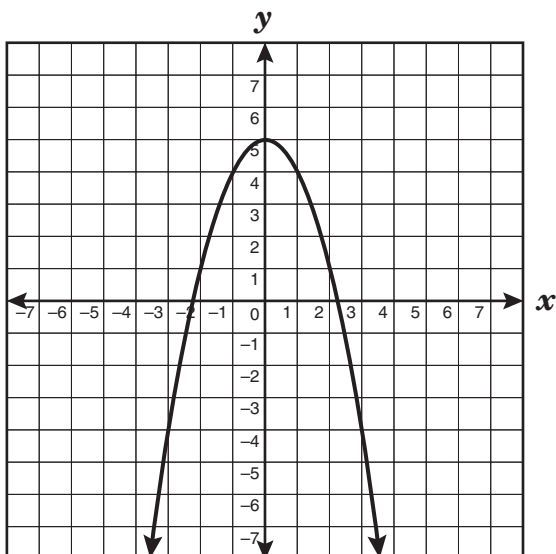

- A $y = x^2 + x + 5$
- B $y = x^2 + 5$
- C $y = -x^2 + 5$
- D $y = -x^2 + x + 5$

- 18 The net of a regular triangular pyramid is shown below. Use the ruler on the Mathematics Chart to measure the dimensions of the pyramid to the nearest tenth of a centimeter.

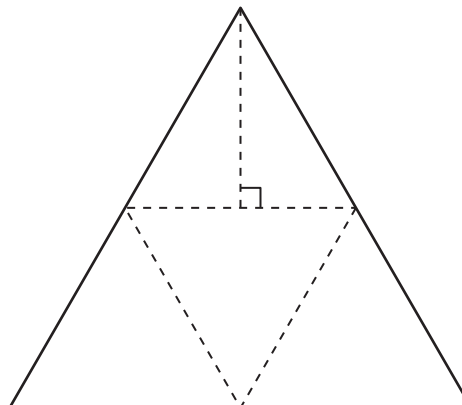

Which of the following best represents the total area of this net?

- F 8 cm^2
- G 16 cm^2
- H 12 cm^2
- J 31 cm^2

- 19 The figure below shows the positions of a surveying crew measuring the distance to a tree across the river.

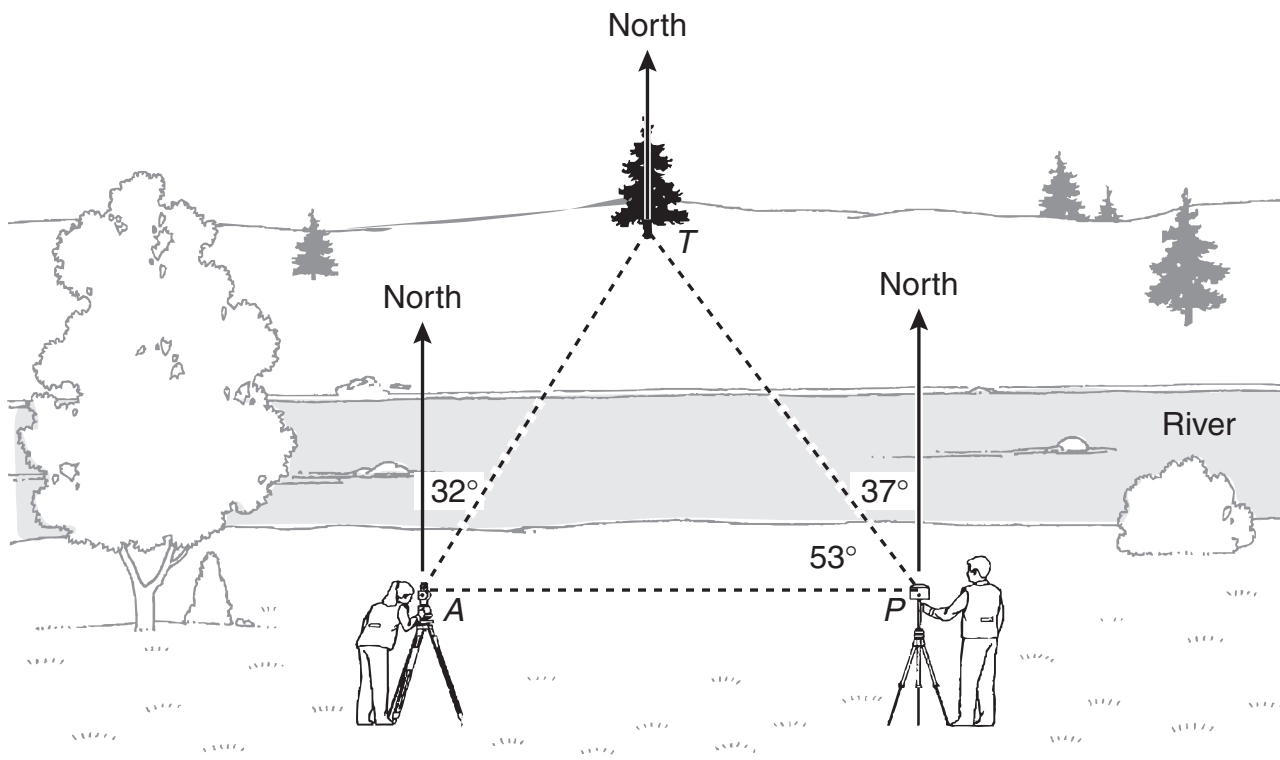

Which of the following best represents the measure of $\angle TAP$?

- A 58°
- B 69°
- C 90°
- D 122°

20 What are the coordinates of the x -intercept of the function graphed below?

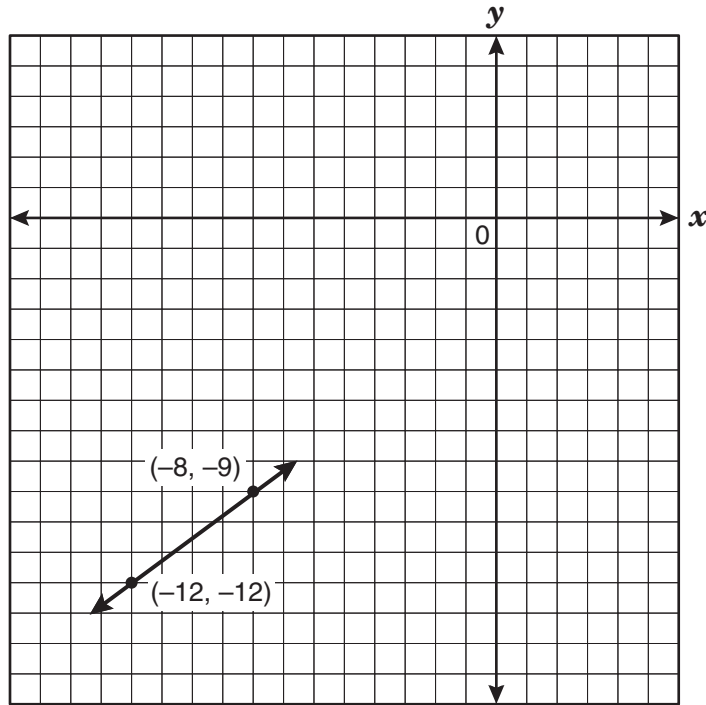

- F** $(4, 0)$
- G** $(-3, 0)$
- H** $(0, 4)$
- J** $(0, -3)$

- 21** A large cheese pizza at Palanzio's Pizzeria costs \$6.80 plus \$0.90 for each topping. The cost of a large cheese pizza at Guido's Pizza is \$7.30 plus \$0.65 for each topping. How many toppings need to be added to a large cheese pizza from Palanzio's Pizzeria and Guido's Pizza in order for the pizzas to cost the same, not including tax?

Record your answer and fill in the bubbles on your answer document. Be sure to use the correct place value.

- 22** Which of the following is a sufficient condition to show that a certain equation does not represent a linear function?
- F** The graph of the equation has a slope of zero.
 - G** The graph of the equation has the set of all real numbers as its domain.
 - H** The graph of the equation has an undefined slope.
 - J** The graph of the equation has exactly one y -intercept.

- 23** The mass of Earth is close to 5.97×10^{24} kilograms, and the mass of Venus is close to 4.87×10^{24} kilograms. What is the combined mass of both planets?

- A** 1.08×10^{25} kg
- B** 2.91×10^{49} kg
- C** 1.08×10^{48} kg
- D** 1.10×10^{24} kg

- 24** The polygon $RSTU$ is shown below.

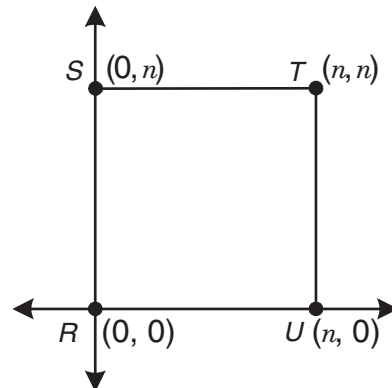

Which expression represents the area of this polygon?

- F** $4n^2$
- G** $4n$
- H** $2n$
- J** n^2

- 25 The graph below shows the number of lightbulbs in thousands that the Electric Lightbulb Company sold from 1998 to 2001.

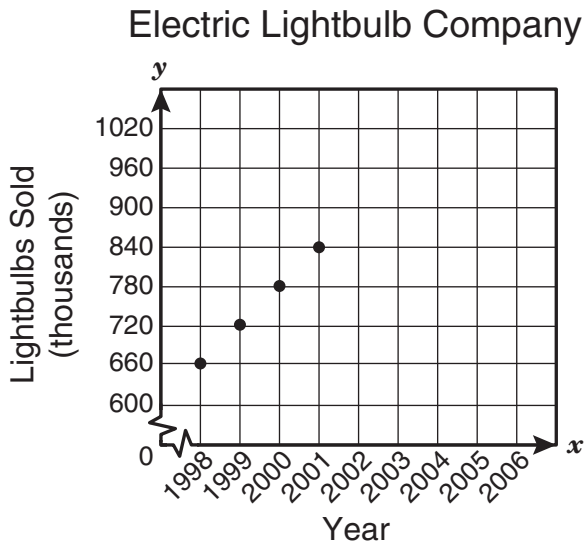

If the trend shown on the graph continues, in what year can the Electric Lightbulb Company first expect to sell more than 1.3 million lightbulbs?

- A 2010
- B 2008
- C 2009
- D 2011

- 26 Brian was 1 out of 25 students who took a practice college entrance exam. No two students scored the same on the exam. If x represents the number of students who scored higher than Brian, which expression represents the number of students who scored lower than Brian?

- F $24 - x$
- G $x - 24$
- H $25 - x$
- J $x - 25$

- 27 A diagonal walkway through a park is 18 meters long. If the park is a square, how long is one of its sides to the nearest tenth of a meter?

- A 9.0 m
- B 12.7 m
- C 18.0 m
- D 25.5 m

- 28 The circle graph below shows the different kinds of garbage collected in the year 2000 according to the Environmental Protection Agency.

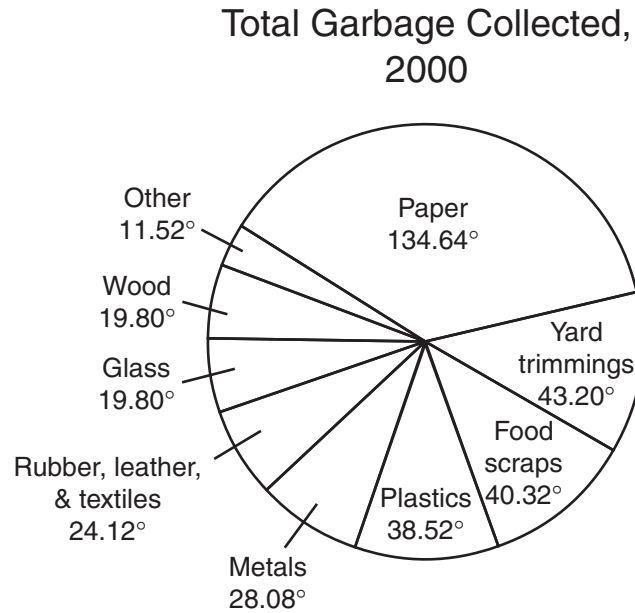

According to this information, which of the following combinations of items is closest to $\frac{2}{3}$ of the garbage collected in the year 2000?

- F** Paper, food scraps, plastics, and other
- G** Paper, yard trimmings, food scraps, and metals
- H** Paper, yard trimmings, plastics, and glass
- J** Paper, food scraps, plastics, and wood

29 Which of the following sets of numbers represents the side lengths in units of a right triangle?

- A 5, 3.2, 4.1
- B 3.6, 6, 4.8
- C 4.5, 8, 6.7
- D 8.5, 5.2, 10

30 If $(5\frac{1}{3}, y)$ is a solution to the equation $5x - 4y - 20 = 0$, what is the value of y ?

- F $-11\frac{2}{3}$
- G $8\frac{4}{15}$
- H $\frac{4}{15}$
- J $1\frac{2}{3}$

31 The regular octagon below shows selected positions on a combination lock.

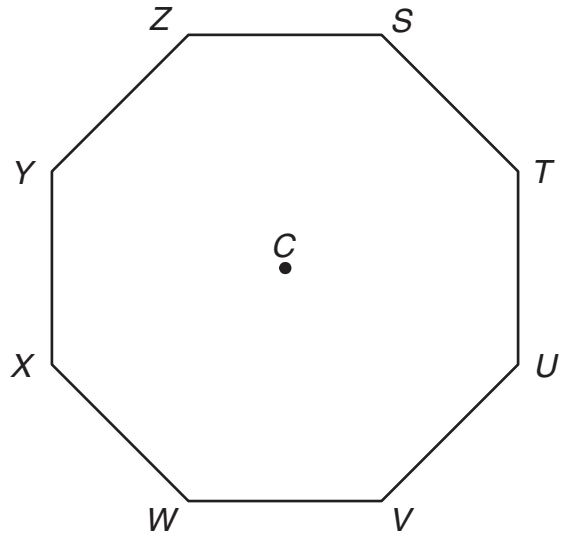

The dial of the lock is turned 90° clockwise and then 45° counterclockwise. Which pair of points can describe the starting and ending points of a marker on the dial of this lock?

- A T to U
- B S to V
- C W to V
- D Z to W

- 32 Mr. Norstam has just released a weather balloon with a diameter of about 3 feet. As the weather balloon rises, it will expand and eventually burst because of the changes in the atmospheric pressure.

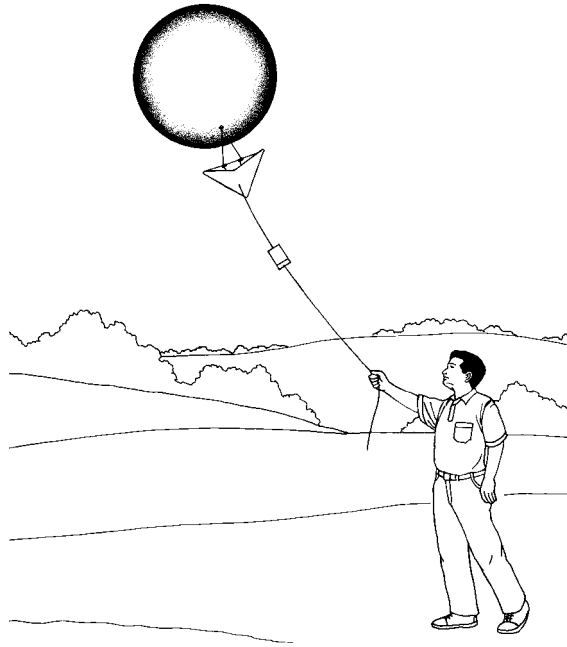

If the weather balloon rises and expands to 1.5 times its diameter before it bursts, what will be its change in volume?

- F The volume will increase to less than 2 times the original volume.
- G The volume will increase to between 2 and 3 times the original volume.
- H The volume will increase to between 3 and 4 times the original volume.
- J The volume will increase to between 4 and 5 times the original volume.

- 33 If the slope of the equation $y = -\frac{3}{5}x + 4$ is changed to $\frac{3}{5}$ and the y -intercept is changed to $(0, -4)$, which statement best describes this situation?

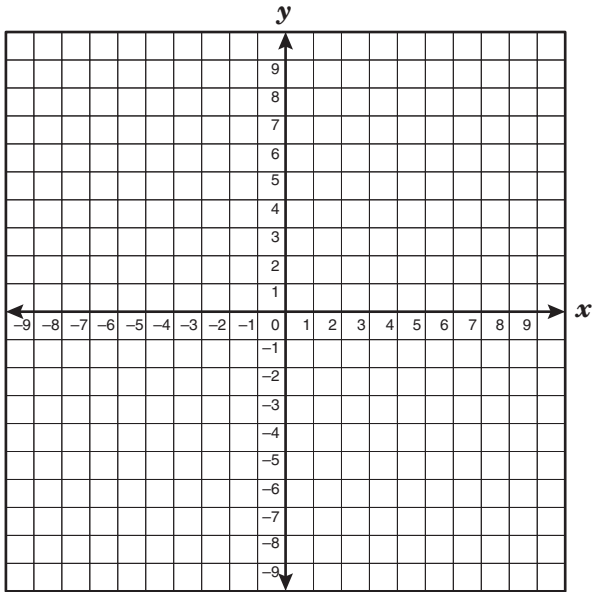

- A The new line is perpendicular to the original line.
- B The new line is parallel to the original line.
- C The new line and the original line have the same y -intercept.
- D The new line and the original line have the same x -intercept.

- 34 Karen, Simone, and Cameron contributed \$64 altogether to pay their phone bill. Karen's contribution was four dollars more than twice as much as Cameron's. Karen's contribution was three times as much as Simone's. What was the amount of Cameron's contribution?

- F \$36
- G \$16
- H \$12
- J Not here

- 35 Mr. Jenkins designed a true-false science exam. The ratio of true answers to false answers is 5:3. Which is closest to the percentage of true answers on Mr. Jenkins's science exam?

- A 53%
- B 60%
- C 38%
- D 63%

- 36 The graph below represents which type of parent function?

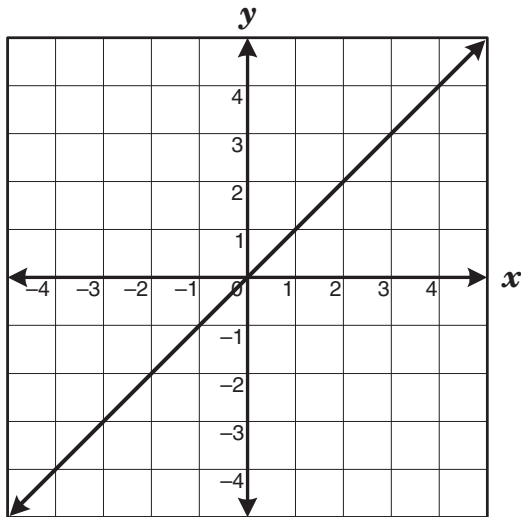

- F Exponential
- G Absolute value
- H Linear
- J Quadratic

- 37 Mitesh is m years old, and his brother Hiren is h years old. Which statement best describes the inequality $m \geq h + 3$?

- A Mitesh is at least 3 times as old as Hiren.
- B Mitesh is at least 3 years older than Hiren.
- C Hiren is more than 3 years older than Mitesh.
- D Hiren is more than 3 times as old as Mitesh.

- 38 Taylor drove down the street to the recreation center. He passed a library, then a playground, and finally a hospital before arriving at the recreation center. The library is 1.7 kilometers from the hospital. The playground is 1.5 kilometers from the recreation center and 0.6 kilometer from the hospital. Which of the following best represents the distance from the library to the recreation center?

- F 3.8 km
- G 2.0 km
- H 3.2 km
- J 2.6 km

- 39 In 2002, people in Laredo, Texas, erected the tallest flagpole in the United States. It can be seen from miles away.

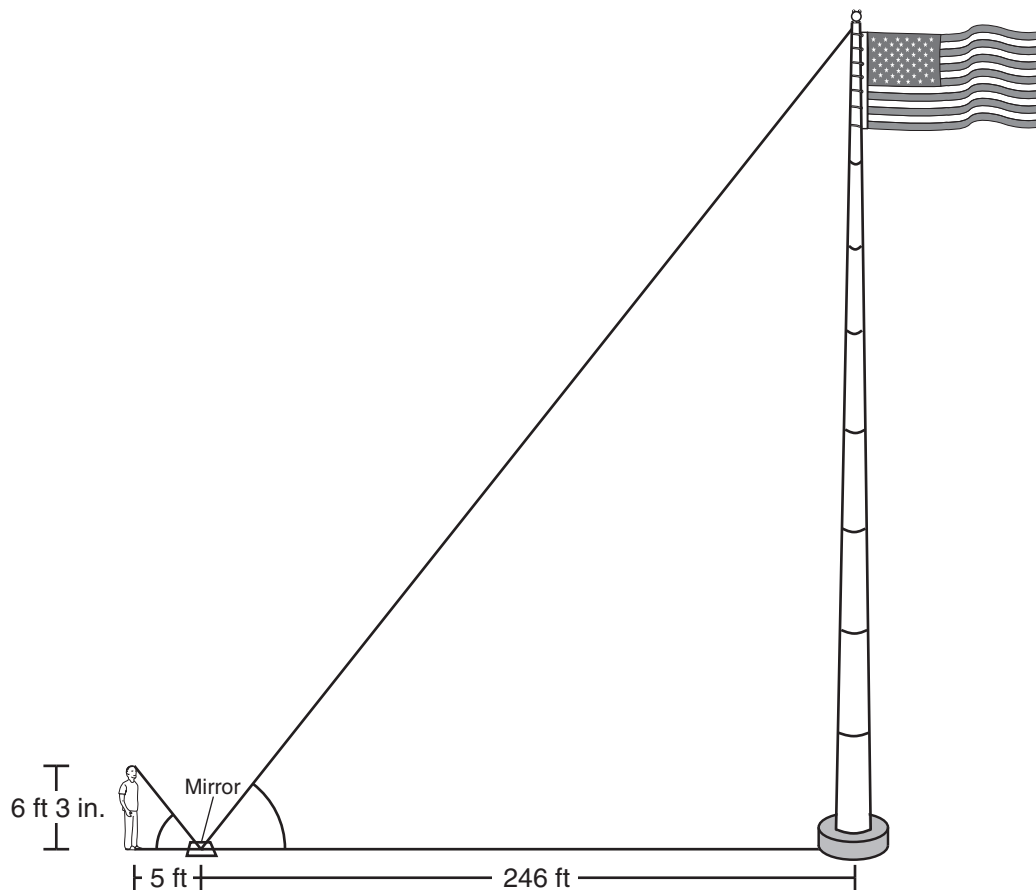

According to the information shown in the drawing, what is the approximate height of the flagpole?
(The drawing is not drawn to scale.)

- A 308 feet
- B 295 feet
- C 205 feet
- D 197 feet

- 40 $\triangle RST$ is a right triangle.

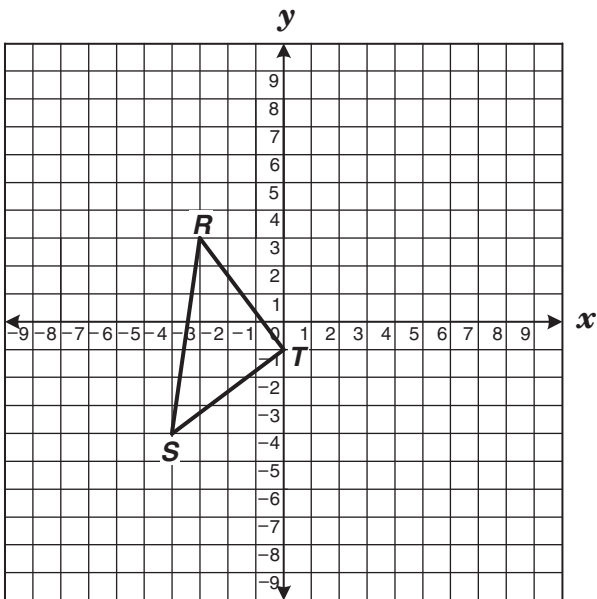

If the equation of the line containing \overline{ST} is $y = \frac{3}{4}x - 1$, which of the following best represents the equation of the line containing \overline{RT} ?

F $y = \frac{4}{3}x - 1$

G $y = -\frac{4}{3}x - 1$

H $y = -\frac{3}{4}x - 1$

J $y = \frac{3}{4}x - 1$

- 41 A salesman at a jewelry store earns a salary of \$295 per week plus a commission of 15% of his weekly sales. If the salesman earned \$936.30 in a week, what was the amount of his sales for the week?

A \$4275.34

B \$5947.07

C \$2115.93

D \$1371.75

- 42 If y varies directly with x and y is 14 when x is 6, which of the following represents this situation?

F $y = 20x$

G $y = \frac{7}{3}x$

H $y = 8x$

J $y = \frac{3}{7}x$

- 43 Which ordered pairs form the vertices of an isosceles trapezoid?

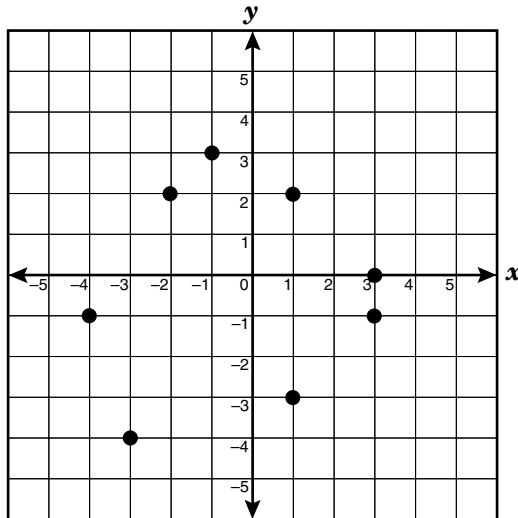

- A (1, 2), (3, -1), (-3, -4), and (-4, -1)
B (1, 2), (3, -1), (-4, -1), and (-2, 2)
C (-1, 3), (3, -1), (-2, 2), and (-4, -1)
D (-1, 3), (-4, -1), (-2, 2), and (3, 0)

-
- 44 Simplify the algebraic expression $\frac{3}{5}(15a^2b - 40ab^2) + \frac{2}{3}(33ab^2 - 6a^2b)$.

- F $5a^2b - 2ab^2$
G $31a^2b - 28ab^2$
H $a^2b + 3ab^2$
J $15a^2b + 18ab^2$

45 Look at the diagram below.

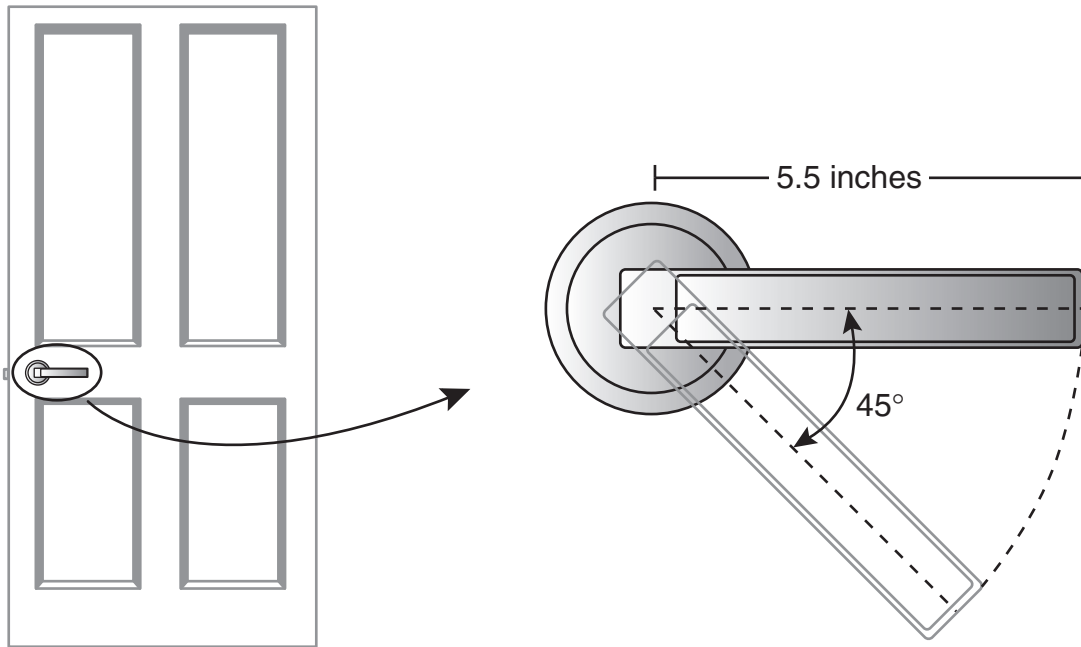

When the door handle is pushed down to open the door, it makes a 45° angle with its former position. What is the approximate arc length of the path traveled by the outside end of the door handle when the handle is pushed down?

- A 34.56 in.
- B 11.88 in.
- C 4.32 in.
- D 2.16 in.

- 46 If the perimeter of the equilateral triangle shown below is 37 centimeters, what is the approximate area of the triangle?

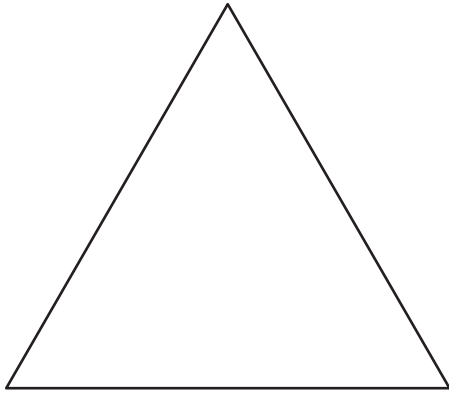

- F 132 cm^2
G 54 cm^2
H 33 cm^2
J 66 cm^2

- 47 Which of the following 3-dimensional figures is made from a set of points in space that are equidistant from a fixed point?

- A Cylinder
B Sphere
C Cube
D Tetrahedron

- 48 Thalia played a word game in which she had a minute to create 5- and 6-letter words from a given word. The given word was *wonderful*. Thalia scored 7 points for each 5-letter word she created and 15 points for each 6-letter word she created. Which of the following is not a possible value for the total points Thalia scored?

- F 37
G 46
H 58
J 59

- 49 A physical education class had 20 students. The table below shows the students' grades and the number of days each student was absent.

Grade Compared with Attendance

Grade	Number of Days Absent
A	0, 3, 2, 2, 1, 1, 4
Less than A	4, 5, 9, 7, 6, 3, 5, 3, 6, 5, 8, 7, 9

Which conclusion about the students in this class is true?

- A Each student who earned a grade of A was absent fewer than 4 days.
 - B Each student who was absent fewer than 4 days earned a grade of A.
 - C Each student who was absent more than 2 days did not earn a grade of A.
 - D Each student who did not earn a grade of A was absent more than 2 days.
-

- 50 Look at the figure shown below.

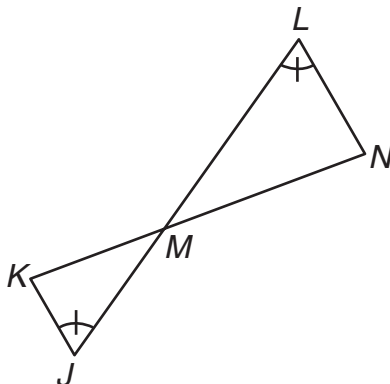

If $\triangle MKJ \sim \triangle MNL$, which of the following must be true?

- F $\angle JKM \cong \angle NLM$, because corresponding angles of similar triangles are congruent.
- G $\frac{MK}{MN} = \frac{KJ}{NL}$, because the ratios of the lengths of corresponding sides of similar triangles are equal.
- H $\frac{KJ}{LN} = \frac{ML}{MK}$, because the ratios of the lengths of corresponding sides of similar triangles are equal.
- J $\angle KJM \cong \angle MNL$, because corresponding angles of similar triangles are congruent.

51 Look at the equations shown below.

$$y = \frac{4}{5}x^2 + 3, \quad y = \frac{4}{5}x^2, \quad y = \frac{4}{5}x^2 - 5, \quad y = \frac{4}{5}x^2 + \frac{3}{5}$$

Which of the following statements is true for the graphs of all the equations given?

- A The graphs are congruent and open downward.
- B The graphs open upward and are symmetrical about the y -axis.
- C The graphs are congruent and are listed from narrowest to widest.
- D The graphs open downward and are symmetrical about the y -axis.

52 An oyster provides approximately 17 calories, and a shrimp provides approximately 26 calories. Jay wants to consume no more than 300 calories eating oysters and shrimp. Which inequality best represents the number of oysters, x , and the number of shrimp, y , that Jay can eat and stay within this limit?

- F $(17 + 26)(x + y) > 300$
- G $(17 + x) + (26 + y) > 300$
- H $(17 + 26)(x + y) \leq 300$
- J $17x + 26y \leq 300$

53 Which of the following polynomial equations best represents this graph?

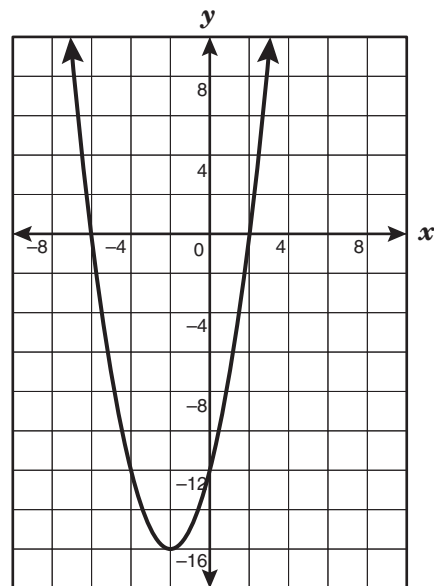

- A $(x + 6)(x - 2) = y$
- B $(x - 2)(x - 16) = y$
- C $(x - 6)(x + 2) = y$
- D $(x + 2)(x + 16) = y$

54 Look at the figures and the table below.

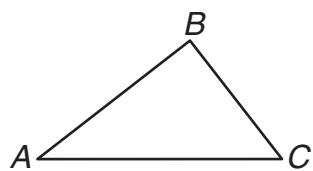

Stage 1

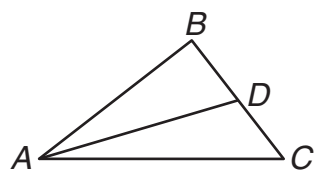

Stage 2

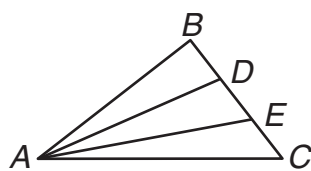

Stage 3

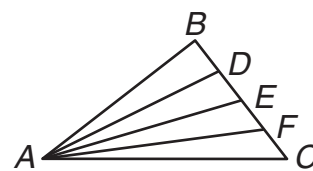

Stage 4

Stage	Number of Triangles
1	1
2	3
3	6
4	10

How many triangles will the n th stage contain?

F $2^n - 1$

G $\frac{n^2 + n}{2}$

H $2n - 1$

J $\frac{n^2 + 2}{2}$

55 On a certain math problem, Cynthia mistakenly divided a number by 4 and then subtracted 24 and got 12 for her answer. After reading the problem again, she realized that she should have subtracted 24 before dividing by 4. What was the correct answer?

- A -48
- B -28
- C 30
- D 144

56 The table below shows the relationship between x and y .

x	y
-1	-1
0	1
1	3
2	17

Which function best represents the relationship between the quantities in the table?

- F $y = 2x + 1$
- G $y = 2x^3 + 1$
- H $y = 2x^2 - 3$
- J $y = 2x^2 + 4x + 1$

57 The midpoint of the diagonals of rectangle $PTQW$ is $(-0.5, 1)$. The coordinates of P are $(-3.5, 6)$. What are the coordinates of Q ?

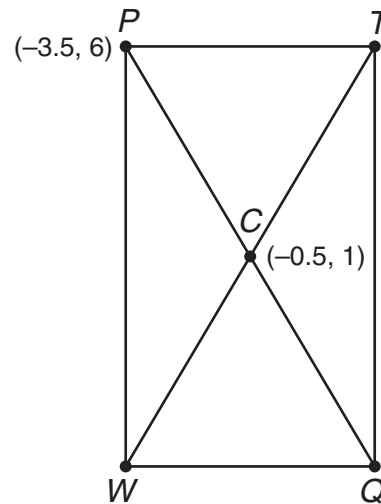

- A $(-2, 3.5)$
- B $(-6.5, 11)$
- C $(-1.5, 2.5)$
- D $(2.5, -4)$

- 58 The graph below shows the number of pies and the number of cakes that the students in the art club need to sell at the school bake sale in order to raise \$150.

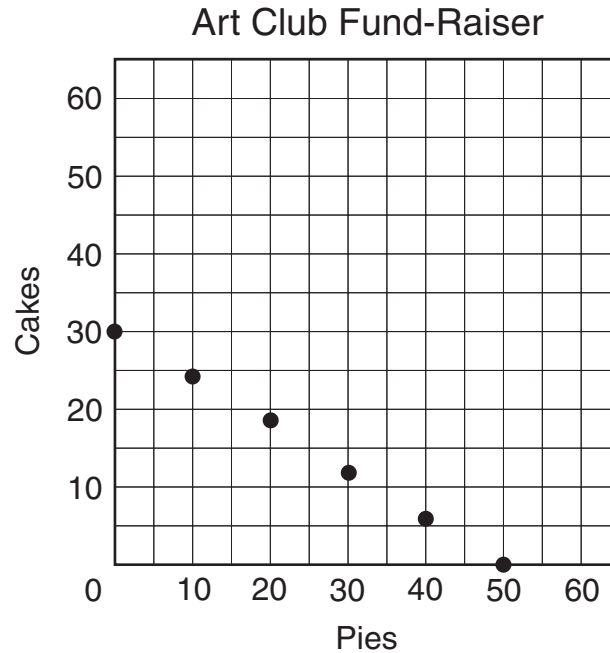

Which of the following represents the maximum number of cakes the art club could sell to raise exactly \$150?

- F 40
 - G 25
 - H 50
 - J 30
-
- 59 Ms. Collins's car traveled between 25 and 29 miles per gallon of gasoline on a recent road trip. If the road trip was 614 miles, which could be the number of gallons of gasoline that Ms. Collins used during this road trip?
- A 23 gal
 - B 29 gal
 - C 21 gal
 - D 25 gal

- 60 The drawing shows the top view of a structure built with cubes as well as the number of cubes in each column of the structure.

4	3	2	Right
2	3	1	
1	2	1	
Front			

Which 3-dimensional view represents the same structure?

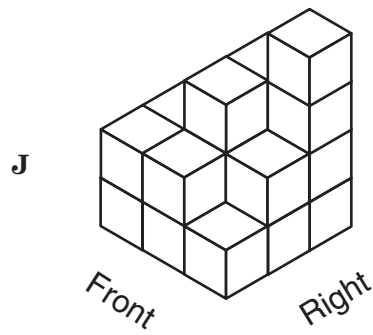
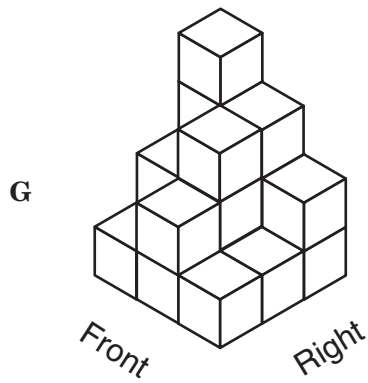
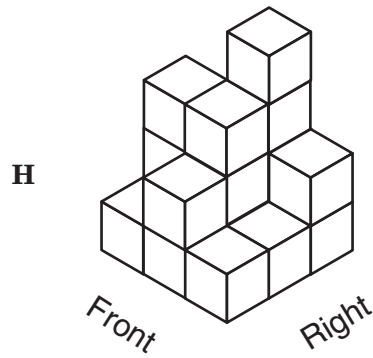
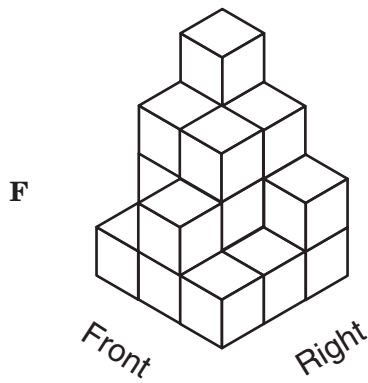

BE SURE YOU HAVE RECORDED ALL OF YOUR ANSWERS
ON THE ANSWER DOCUMENT.



