

STUDENT NAME _____

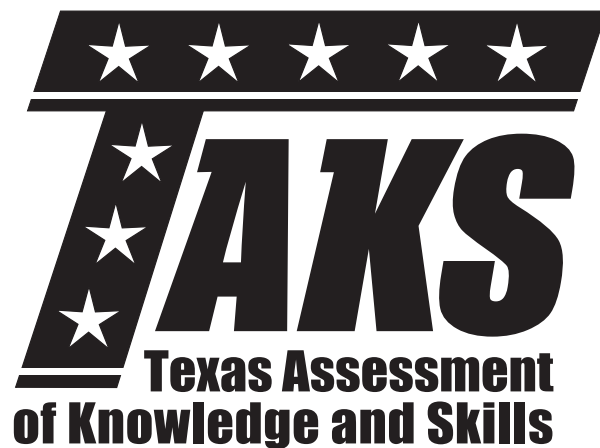

EXIT LEVEL
ENGLISH LANGUAGE ARTS
MATHEMATICS
SCIENCE
SOCIAL STUDIES

Administered April 2006

Mathematics Chart

LENGTH

Metric	Customary
1 kilometer = 1000 meters	1 mile = 1760 yards
1 meter = 100 centimeters	1 mile = 5280 feet
1 centimeter = 10 millimeters	1 yard = 3 feet
	1 foot = 12 inches

CAPACITY AND VOLUME

Metric	Customary
1 liter = 1000 milliliters	1 gallon = 4 quarts
	1 gallon = 128 ounces
	1 quart = 2 pints
	1 pint = 2 cups
	1 cup = 8 ounces

MASS AND WEIGHT

Metric	Customary
1 kilogram = 1000 grams	1 ton = 2000 pounds
1 gram = 1000 milligrams	1 pound = 16 ounces

TIME

1 year = 365 days
1 year = 12 months
1 year = 52 weeks
1 week = 7 days
1 day = 24 hours
1 hour = 60 minutes
1 minute = 60 seconds

Metric and customary rulers can be found on the separate Mathematics Chart.

Mathematics Chart

Perimeter	rectangle	$P = 2l + 2w$ or $P = 2(l + w)$
Circumference	circle	$C = 2\pi r$ or $C = \pi d$
Area	rectangle	$A = lw$ or $A = bh$
	triangle	$A = \frac{1}{2}bh$ or $A = \frac{bh}{2}$
	trapezoid	$A = \frac{1}{2}(b_1 + b_2)h$ or $A = \frac{(b_1 + b_2)h}{2}$
	circle	$A = \pi r^2$
Surface Area	cube	$S = 6s^2$
	cylinder (lateral)	$S = 2\pi rh$
	cylinder (total)	$S = 2\pi rh + 2\pi r^2$ or $S = 2\pi r(h + r)$
	cone (lateral)	$S = \pi rl$
	cone (total)	$S = \pi rl + \pi r^2$ or $S = \pi r(l + r)$
	sphere	$S = 4\pi r^2$
Volume	prism or cylinder	$V = Bh^*$
	pyramid or cone	$V = \frac{1}{3}Bh^*$
	sphere	$V = \frac{4}{3}\pi r^3$
<i>*B represents the area of the Base of a solid figure.</i>		
Pi	π	$\pi \approx 3.14$ or $\pi \approx \frac{22}{7}$
Pythagorean Theorem		$a^2 + b^2 = c^2$
Distance Formula		$d = \sqrt{(x_2 - x_1)^2 + (y_2 - y_1)^2}$
Slope of a Line		$m = \frac{y_2 - y_1}{x_2 - x_1}$
Midpoint Formula		$M = \left(\frac{x_1 + x_2}{2}, \frac{y_1 + y_2}{2} \right)$
Quadratic Formula		$x = \frac{-b \pm \sqrt{b^2 - 4ac}}{2a}$
Slope-Intercept Form of an Equation		$y = mx + b$
Point-Slope Form of an Equation		$y - y_1 = m(x - x_1)$
Standard Form of an Equation		$Ax + By = C$
Simple Interest Formula		$I = prt$

DIRECTIONS

Read each question. Then fill in the correct answer on your answer document. If a correct answer is not here, mark the letter for “Not here.”

SAMPLE A

Find the slope of the line $2y = 8x - 3$.

A $-\frac{3}{2}$

B 4

C 8

D Not here

SAMPLE B

Janice uses a rectangular box to store her art supplies. The dimensions of the rectangular box are 22.5 inches by 14 inches by 11.5 inches. What is the volume of this box in cubic inches?

Record your answer and fill in the bubbles on your answer document. Be sure to use the correct place value.



1 The student council at Jefferson High School sold a total of 220 brownies and cookies during its fund-raiser. Each brownie sold for \$0.75, and each cookie sold for \$0.50. The student council made \$136.50 from the sales of brownies and cookies. Which system of linear equations can be used to find b , the number of brownies sold, and c , the number of cookies sold?

- A $b + c = 220$
 $0.50b + 0.75c = 136.50$
- B $b + c = 136.50$
 $0.75b + 0.50c = 220$
- C $b + c = 136.50$
 $0.50b + 0.75c = 220$
- D $b + c = 220$
 $0.75b + 0.50c = 136.50$

2 $\triangle WXY$ is isosceles.

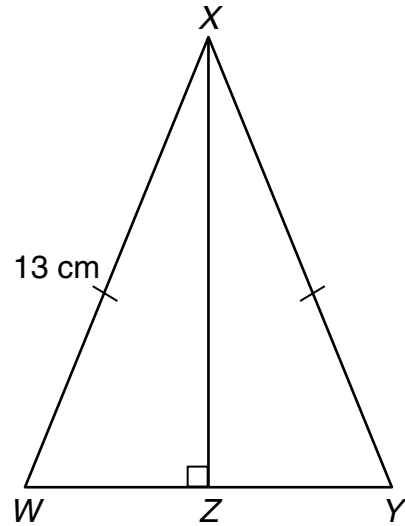

\overline{WY} is 10 centimeters long. Find the length of \overline{XZ} .

- F 5 cm
G 10 cm
H 12 cm
J 13 cm

3 Mr. Kelly's company manufactures a cylindrical soup can that has a diameter of 6 inches and a volume of 226 cubic inches. If the diameter stays the same and the height is doubled, what will happen to the can's volume?

- A It will remain the same.
B It will double.
C It will triple.
D It will quadruple.

- 4 Which graph best represents the line that has a slope of $-\frac{5}{6}$ and contains the point $(4, -3)$?

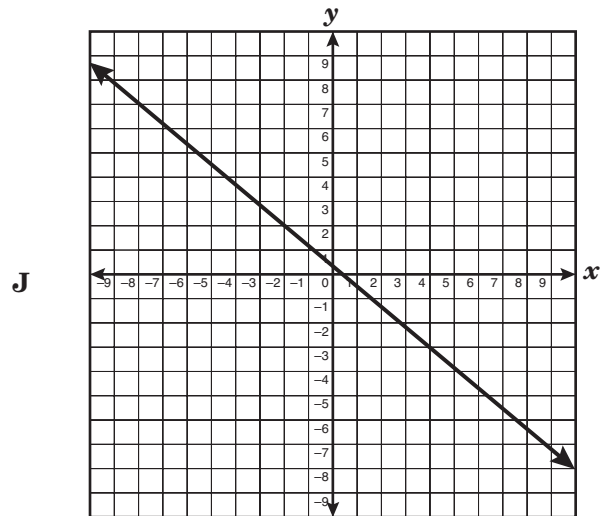
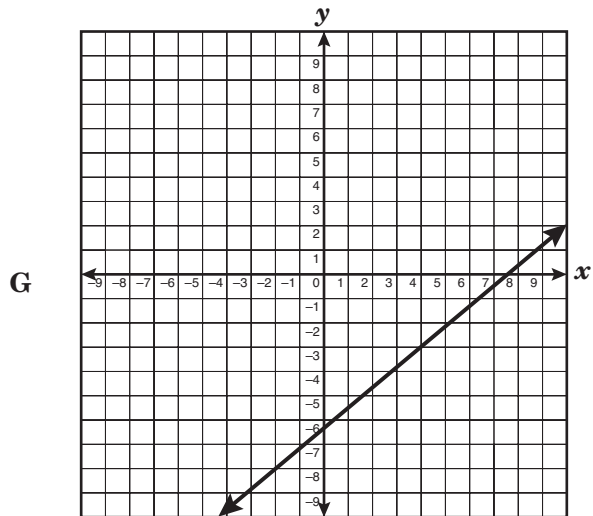
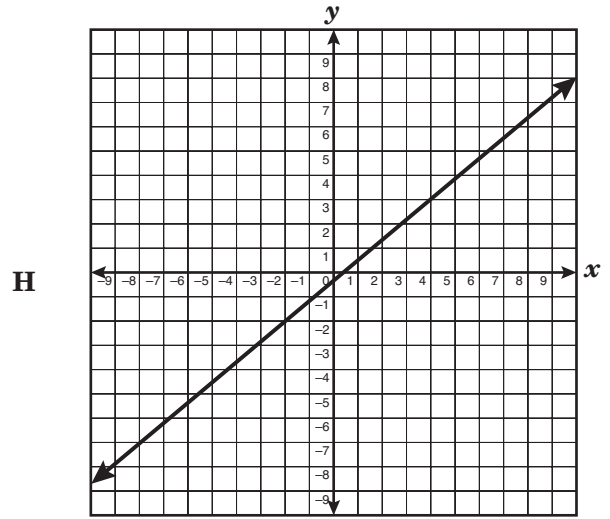
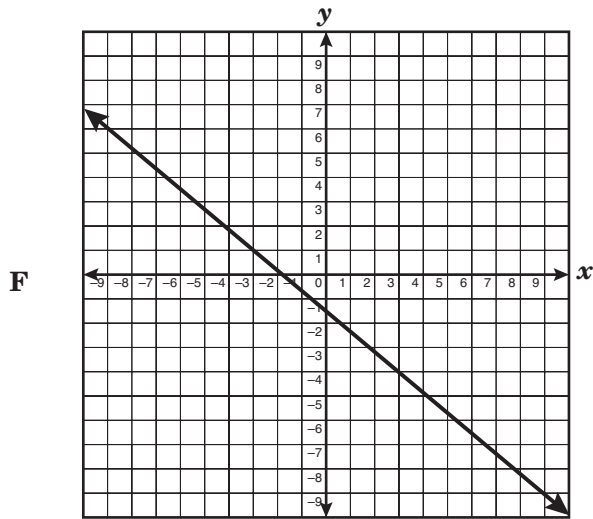

- 5 Amanda, Bonnie, Cindy, and Linda competed in a biathlon consisting of running and swimming events. The table below shows the number of seconds each of them took to complete the parts of the competition.

Name	Running (seconds)	Swimming (seconds)
Amanda	700	540
Bonnie	730	400
Cindy	720	460
Linda	750	330

The top rankings are awarded to the individuals with the fastest combined times. Based on the information given in the table, which event probably determined the outcome of the competition?

- A Running, because the times vary more
- B Swimming, because the times vary more
- C Running, because the times are consistent
- D Swimming, because the times are consistent

- 6 Simplify the polynomial below.

$$-3x(7x - 4) + 6x - (13 - 24x^2)$$

- F $3x^2 + 18x - 13$
- G $-24x^2 - 15x - 17$
- H $-24x^2 + 10x - 17$
- J $3x^2 + 18x + 13$

- 7 The graph of a function of the form $y = ax^2 + c$ is shown below.

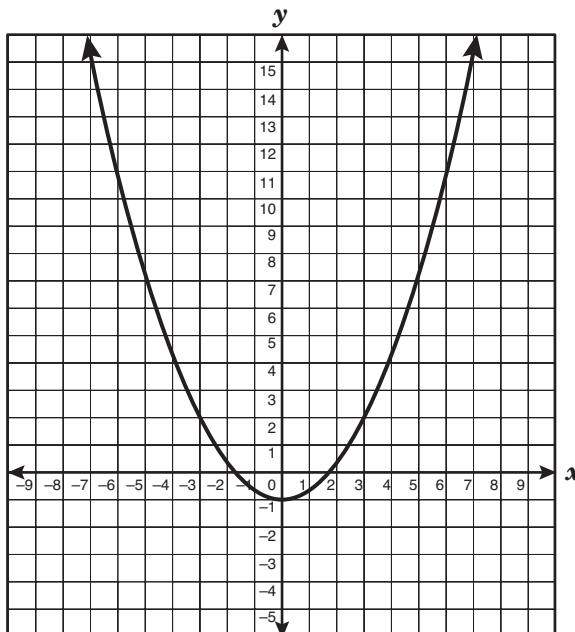

If the graph is translated only up or down to include the ordered pair (6, 7), which of the following equations best represents the resulting graph?

- A $y = -\frac{1}{3}x^2 + 3$
- B $y = \frac{1}{3}x^2 + 1$
- C $y = -\frac{1}{3}x^2 - 10$
- D $y = \frac{1}{3}x^2 - 5$

8 The first 4 stages of a certain fractal are shown below.

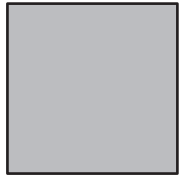

Stage 1

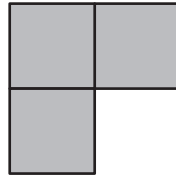

Stage 2

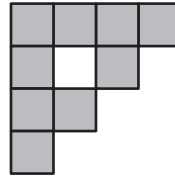

Stage 3

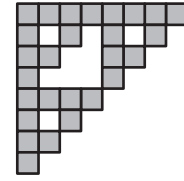

Stage 4

In each stage after the first, each square is divided into 4 squares, and then the bottom right square is removed. If the pattern continues, how many shaded square units will Stage 5 contain?

- F 243
- G 54
- H 81
- J 27

9 Which of the following relationships could not be used to determine the length of \overline{DR} , as shown below?

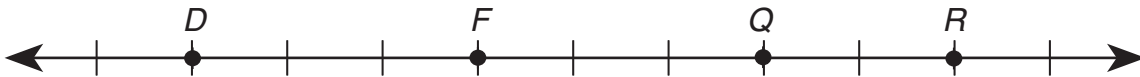

- A $DF + FQ + QR = DR$
- B $DQ + QR = DR$
- C $DQ + FR = DR$
- D $DF + FR = DR$

- 10 How many faces, edges, and vertices does the solid shown below have?

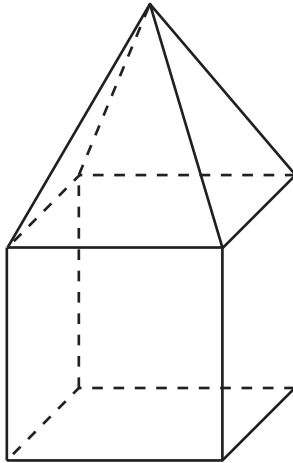

- F** 4 faces, 10 edges, and 7 vertices
G 9 faces, 10 edges, and 8 vertices
H 10 faces, 16 edges, and 9 vertices
J 9 faces, 16 edges, and 9 vertices
- 11 A salesclerk earns \$250 per week plus a commission of $\frac{1}{5}$ of her total sales. If her sales total x dollars, which equation can be used to determine her total weekly earnings?

- A** $y = 250(x + \frac{1}{5})$
B $y = 250x + \frac{1}{5}x$
C $y = 250x + \frac{1}{5}$
D $y = 250 + \frac{1}{5}x$

- 12 Mr. Maxwell asked his students to identify the domain represented by the function graphed below.

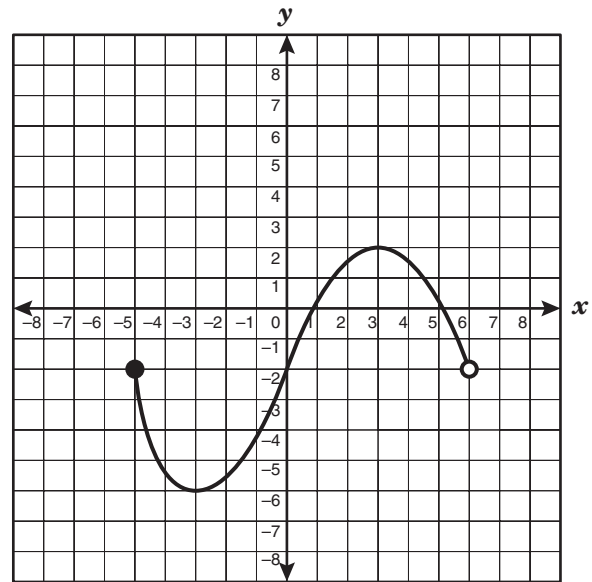

Which of the following student responses is correct?

- F** $-5 \leq x < 6$
G $-6 \leq x \leq 2$
H $-5 \leq x < -2$
J Not here
- 13 An ice-cream vendor made a table showing the relationship between the daily high temperature and the number of ice-cream cones sold per day. What is the dependent quantity in this relationship?
- A** The daily high temperature
B The number of ice-cream cones sold per day
C All of the data in the table
D Cannot be determined

- 14 The diagram below shows the top view of a structure built with identical cubes, as well as the number of cubes in each column of the structure.

2	3	4
2	2	
4	2	1

Front

Which 3-dimensional view best represents the same structure?

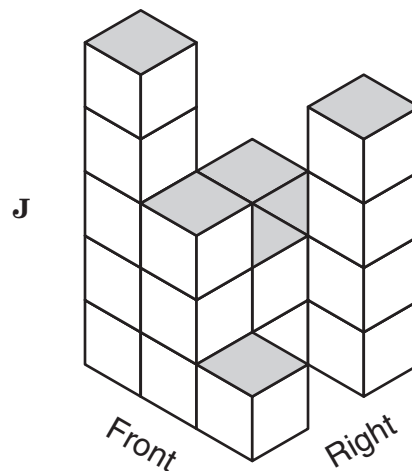
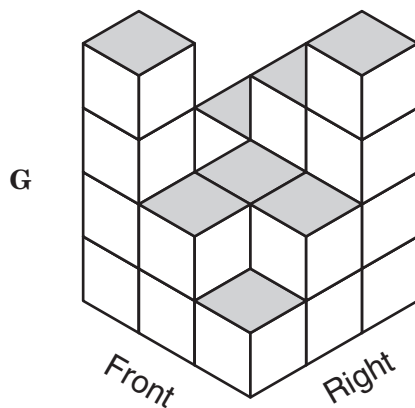
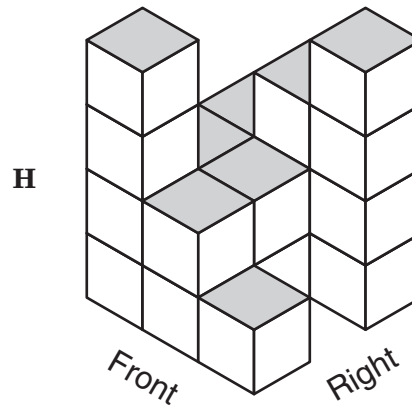
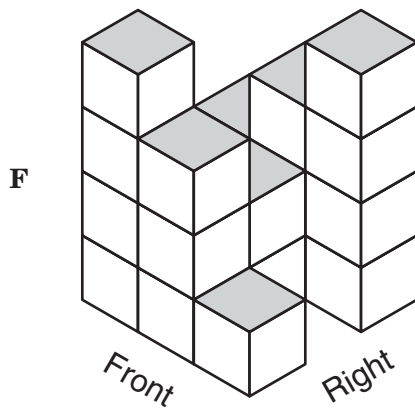

- 15 Mr. Schultz has a garden shaped like an equilateral triangle that measures 11 feet on each side. He has placed a watering hose that extends from the faucet located at a vertex to the opposite side, as shown below.

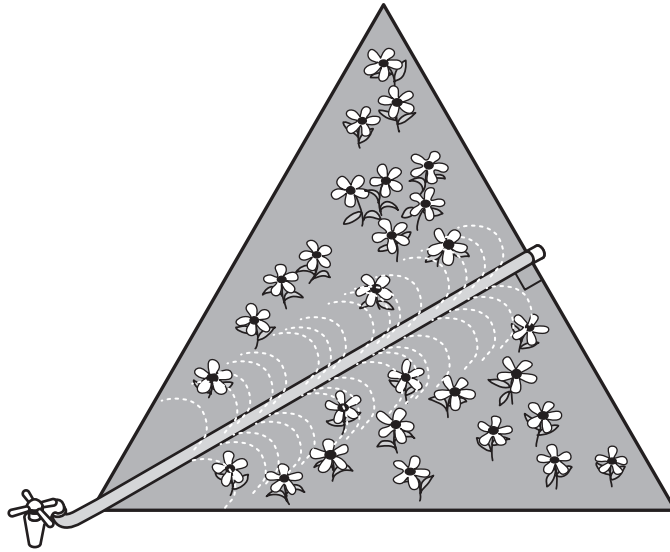

Which is closest to the length of the hose in the garden?

- A 7.8 ft
- B 9.5 ft
- C 6.4 ft
- D 5.5 ft

-
- 16 What is the simplified form of $\frac{(-6a^3b^5)(2a^2b^3)}{-18a^4b^8c^3}$?

- F $-\frac{2a^2b}{3c^3}$
- G $\frac{2a}{3c^3}$
- H $\frac{2a^2b}{3bc^3}$
- J $-\frac{2ab}{3c^3}$

- 17 A biologist noticed that the population of ladybugs in a sample doubled every 3 days. If the initial population sample was 30 ladybugs, what was the population of ladybugs at the end of 9 days?
- A 90
 B 270
 C 120
 D 240

- 18 Which points best represent the roots of the graphed quadratic equation shown below?

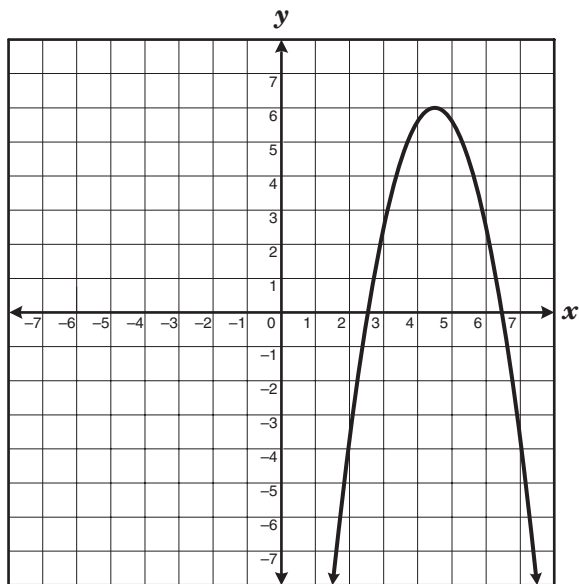

- F $(6\frac{1}{2}, 0)$ and $(4\frac{1}{2}, 6)$
 G $(4\frac{1}{2}, 6)$ and $(2\frac{1}{2}, 0)$
 H $(2\frac{1}{2}, 0)$ and $(6\frac{1}{2}, 0)$
 J $(0, 2\frac{1}{2})$ and $(0, 6\frac{1}{2})$

- 19 Look at the cube shown below.

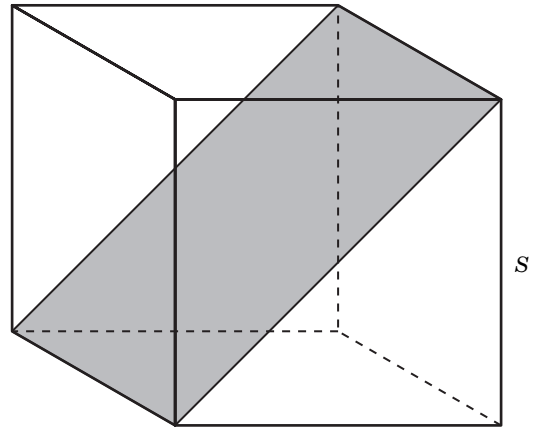

Which equation best represents the area of the shaded rectangle located diagonally in the cube?

- A $A = s^2\sqrt{3}$
 B $A = \frac{s^3}{2}$
 C $A = s^3\sqrt{2}$
 D $A = s^2\sqrt{2}$

- 20 Jackie made a rectangular prism to hold her earrings. The net of the rectangular prism is shown below. Use the ruler on the Mathematics Chart to measure the dimensions of the rectangular prism to the nearest $\frac{1}{4}$ inch.

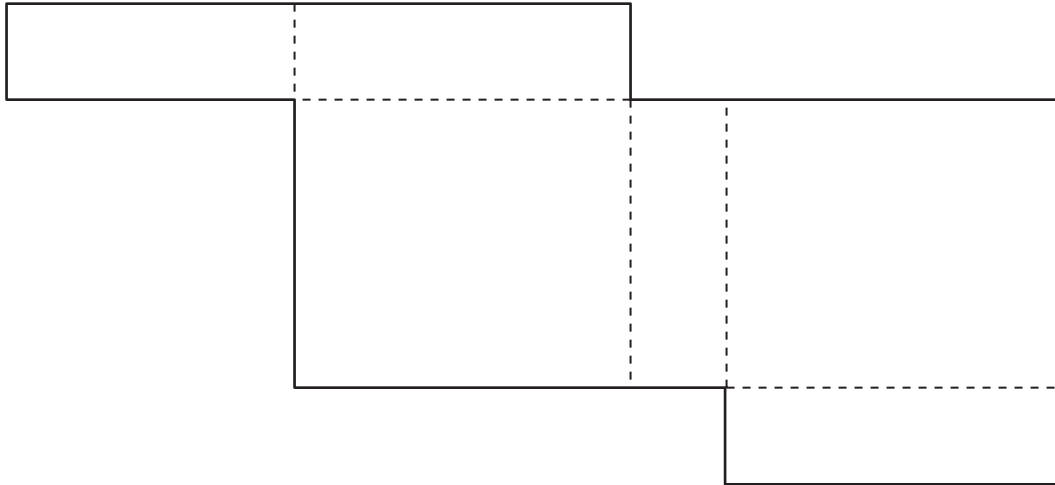

Which is closest to the volume of this rectangular prism?

- F** 4 in.³
G 1.3 in.³
H 8.5 in.³
J 13.5 in.³
-
- 21 The equation $F = \frac{9}{5}C + 32$ represents the relationship between F , the temperature in degrees Fahrenheit, and C , the temperature in degrees Celsius. If the temperature is 104°F, what is the temperature in degrees Celsius?

Record your answer and fill in the bubbles on your answer document. Be sure to use the correct place value.

22 A diagram of a power/volume control knob on a stereo is shown below.

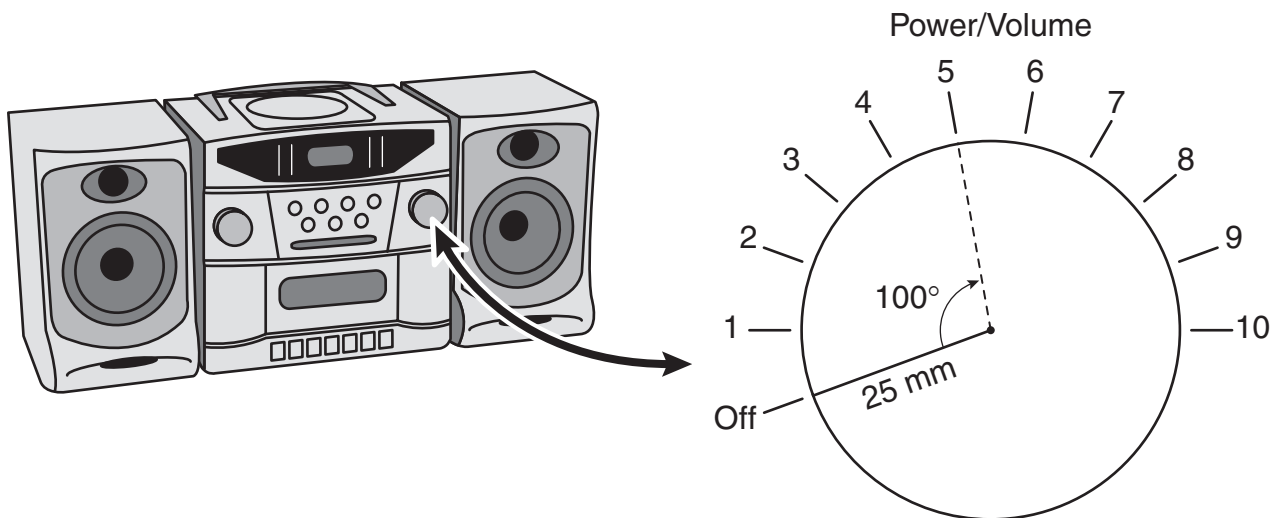

When the stereo is turned on and the knob is turned to a volume level of 5, the knob is rotated 100° from its off position. What is the approximate arc length of the path traveled by the knob's rotation from the off position to a volume level of 5?

- F 545 mm
- G 157 mm
- H 22 mm
- J 44 mm

23 Last Friday a used-car dealer had cars for sale for \$600, \$690, \$695, \$710, \$725, \$750, \$850, \$995, \$995, \$995, and \$1495. Select the most effective measure to use to convince potential customers that the dealer's prices are very low.

- A** Mean
- B** Median
- C** Mode
- D** Range

24 If $r + s = t$ and $x = y$, which of the following must be true?

F $r + s - x = y - t$

G $r + s - t = x + y$

H $r + s + t = x - y$

J $r + s + x = t + y$

25 \overline{AB} is a diameter of the circle shown below.

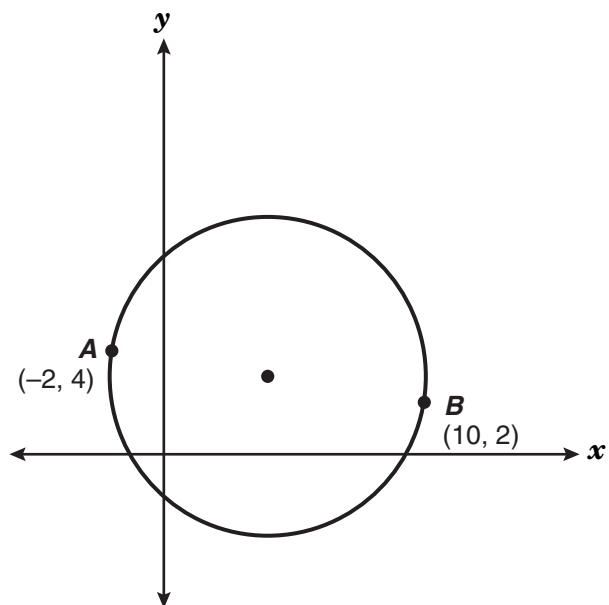

Which is closest to the length of the radius of the circle?

- A 3.1 units
- B 4.3 units
- C 6.1 units
- D 12.2 units

26 The graph of a linear function is shown below.

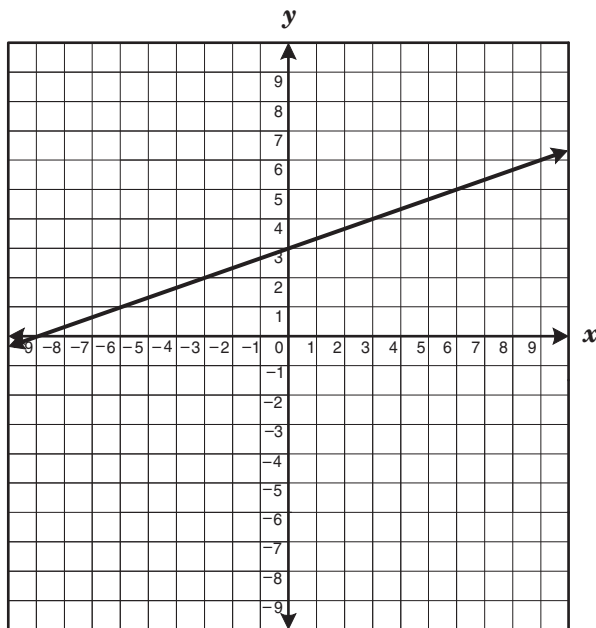

If the line is translated 2 units down, which equation will best describe the new line?

F $y = 3x + 1$

G $y = \frac{1}{3}x + 1$

H $y = 3x + 5$

J $y = \frac{1}{3}x + 5$

- 27 Henry built a wooden storage shed in the shape of a rectangular prism for his tools. The figure below shows the dimensions of the storage shed.

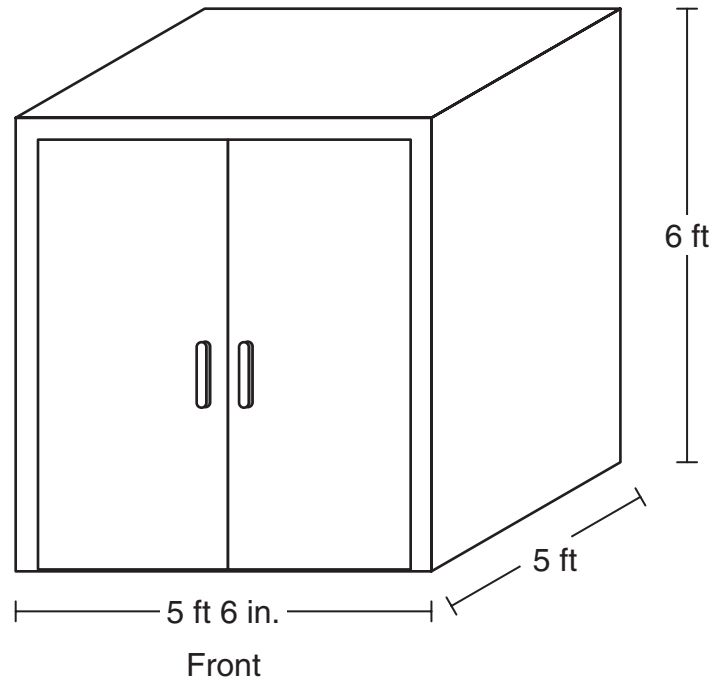

If Henry plans to paint only the top, front, left, and right sides of his shed, which is closest to the surface area that will be painted?

- A 121 ft^2
- B 181 ft^2
- C 154 ft^2
- D 91 ft^2

28 If y is directly proportional to x and $y = 12$ when $x = 16$, what is the value of x when $y = 5$?

F $1\frac{1}{3}$

G $3\frac{3}{4}$

H $6\frac{2}{3}$

J $\frac{3}{4}$

29 For each grading period Mr. Brown gives his students one project and two tests. The project counts as 20% of the students' final grade, and the mean of the 2 test scores counts as the rest of their grade. In Mr. Brown's class Anthony earned a grade of 87 on his first test and a grade of 96 on his second test. Which of the following is a reasonable minimum grade Anthony must score on his project in order to have a final grade of at least 90?

A 66

B 84

C 87

D 92

30 The spreadsheet below contains 20 cells. A cell in a spreadsheet can be identified first by the column letter and then by the row number. For example, the number 10 is found in Cell C4.

	A	B	C	D	E
1	6	-3	7	1	5
2	12	-4	8	2	
3	18	-5	9	3	-35
4	24	-6	10	4	

If the number in Cell A3 = $B4 - 3(E2 + D4)$, which of the following must be the number in Cell E2?

F -21

G -15

H -4

J -12

31 Which net best represents the triangular prism shown below?

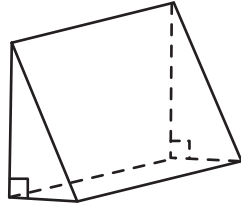

A

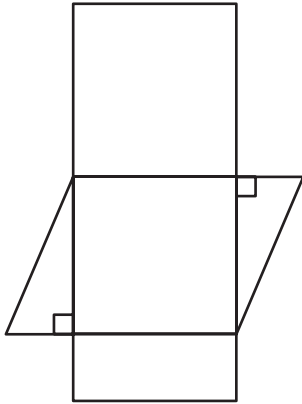

C

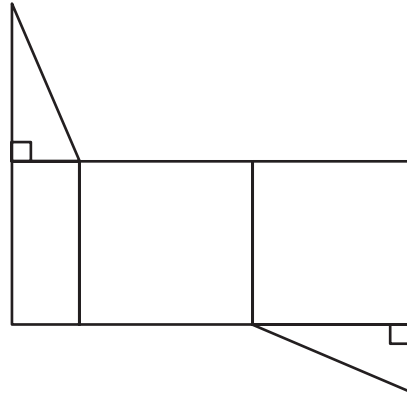

B

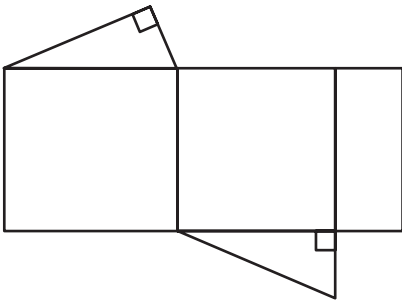

D

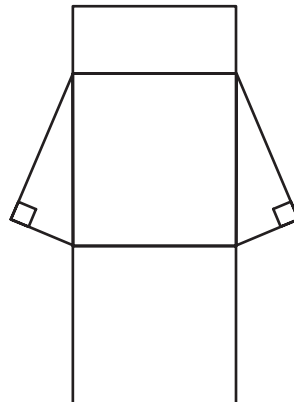

32 The graph of a system of linear equations is shown below.

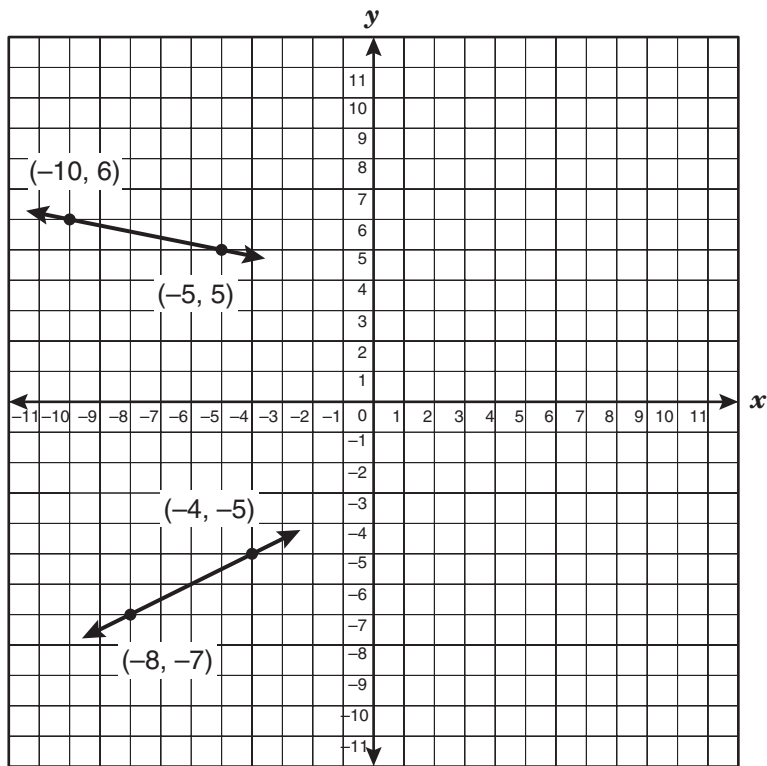

Which of the following is the solution to this system of linear equations?

- F** $(0, 4)$
- G** $(8, 1)$
- H** $(0, -3)$
- J** $(10, 2)$

- 33 Look at the figure shown below.

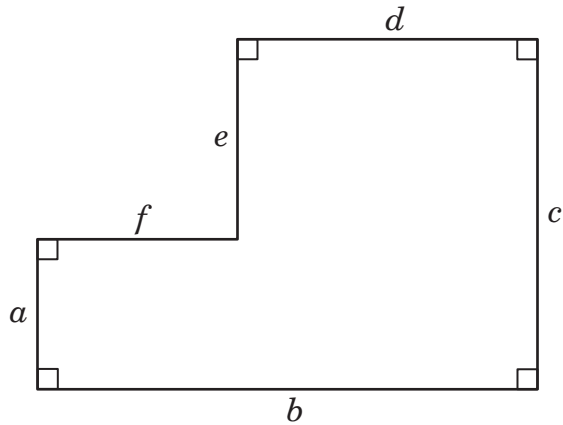

Which expression does not represent the area of the figure?

- A $bc - ef$
 - B $af + ad - de$
 - C $de + af + ad$
 - D $af + cd$
- 34 The Hawthorne Mustangs have won 4 games and lost 6 games this season. Based on these results, which is the best prediction of the number of games the Mustangs must play in order to win 6 games?
- F 8
 - G 9
 - H 12
 - J 15

- 35 The figure below shows a CD in its rectangular storage case.

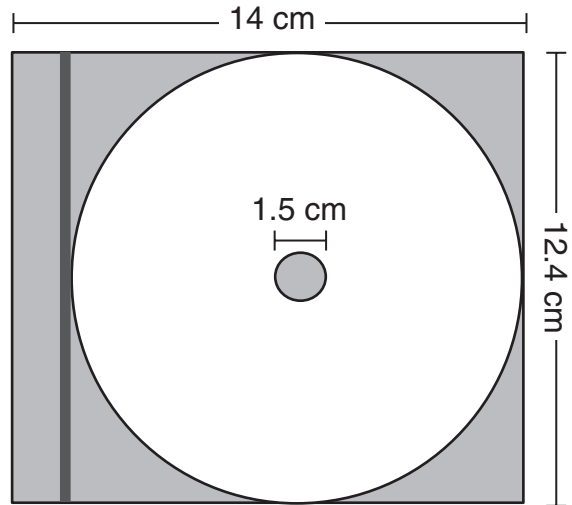

Which is closest to the area of the storage case not occupied by the CD?

- A 55 cm^2
- B 46 cm^2
- C 51 cm^2
- D 60 cm^2

- 36 Parallelogram $WBMP$ is shown on the grid below.

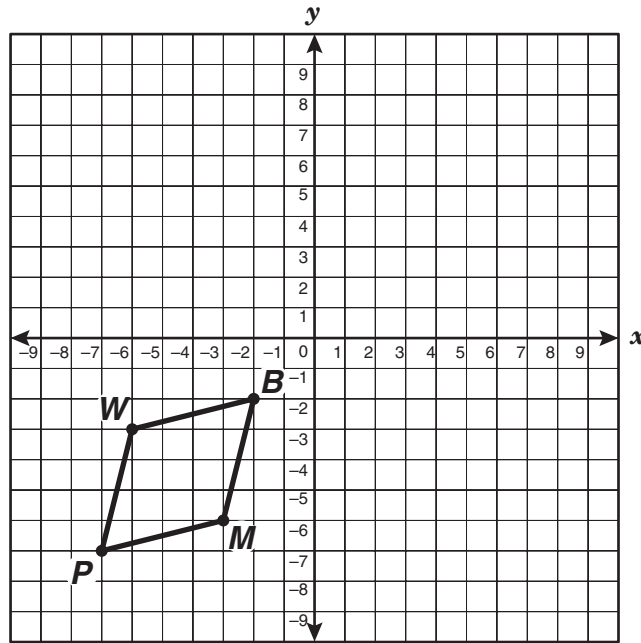

If $WBMP$ is reflected across the line $y = -x$ and then translated 4 units down to become parallelogram $W'B'M'P'$, what will be the coordinates of M' ?

- F** $(-6, -7)$
G $(6, -1)$
H $(6, 7)$
J $(6, 3)$
-
- 37 The profit earned on the sale of tool sets can be represented as the product of the number of tool sets sold and the difference between the selling price and the cost of making each set. The selling price of each tool set is \$19.95, and the cost of making each set is \$4.37. Which equation represents p , the profit, in terms of s , the number of tool sets sold?

- A** $p = s(19.95 - 4.37)$
B $p = s(19.95 + 4.37)$
C $p = 19.95 + 4.37s$
D $p = 19.95s - 4.37$

- 38 The figure below shows a conical cup containing water. The water depth can be represented by x , and the area of the water surface can be represented by A . As the water depth changes, the area of the water surface changes, as shown in the table below.

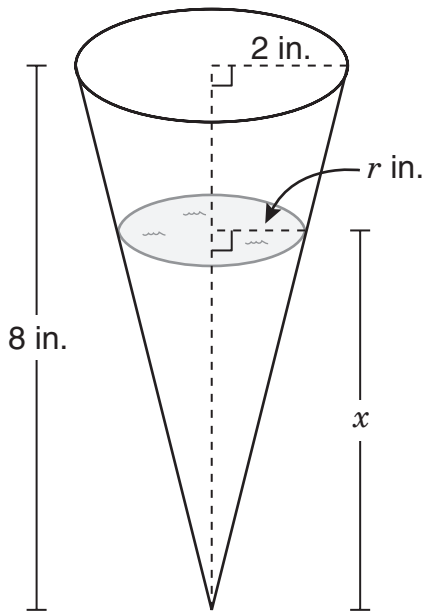

Water Depth (inches)	Area of Water Surface (square inches)
1	$\frac{\pi}{16}$
2	$\frac{\pi}{4}$
3	$\frac{9\pi}{16}$
4	π
8	4π

Which equation best represents the relationship between the area of the water surface and the water depth?

F $A = \frac{\pi(2x - 1)^2}{16} \text{ in.}^2$

G $A = \frac{\pi x}{2} \text{ in.}^2$

H $A = \frac{\pi x^2}{16} \text{ in.}^2$

J $A = \frac{\pi x}{16} \text{ in.}^2$

39 In the figure shown below, $MN = 10$ centimeters.

$$\overleftrightarrow{LM} \parallel \overleftrightarrow{RS} \parallel \overleftrightarrow{YZ}$$

$$\overline{TN} \perp \overline{YZ}$$

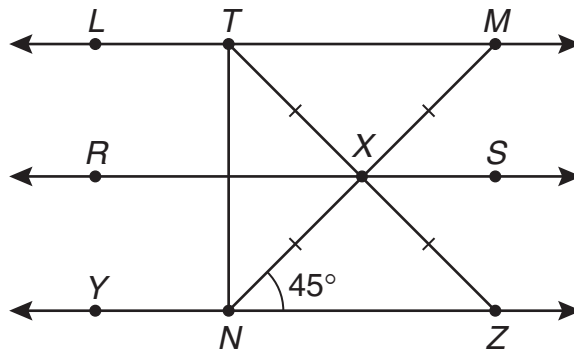

Which is closest to the length of \overline{TN} ?

- A 7 cm
- B 6 cm
- C 17 cm
- D 14 cm

- 40 Casey conducted an experiment and recorded the data in the table shown below.

x	y
1	1
2	2
3	5
4	10

Which equation best describes these data?

- F** $y = x$
G $y = 2x - 1$
H $y = x^2 + x - 1$
J $y = (x - 1)^2 + 1$
- 41 Patti works as a waitress. She earns \$4.50 per hour plus tips and serves an average of 6 customers per hour. If Patti earned \$108 during an 8-hour shift, which amount best represents the average tip per customer?

- A** \$4.00
B \$1.50
C \$3.00
D \$13.50

- 42 The energy of a certain particle is 3.86 joules. If this particle loses 0.105 joule of energy every 30 seconds, what will its energy be after 8 minutes?

- F** 2.18 joules
G 1.68 joules
H 3.02 joules
J 2.29 joules

- 43 Which of the following is the vertex of the graph of the equation $y = -x^2 + 2x + 3$?

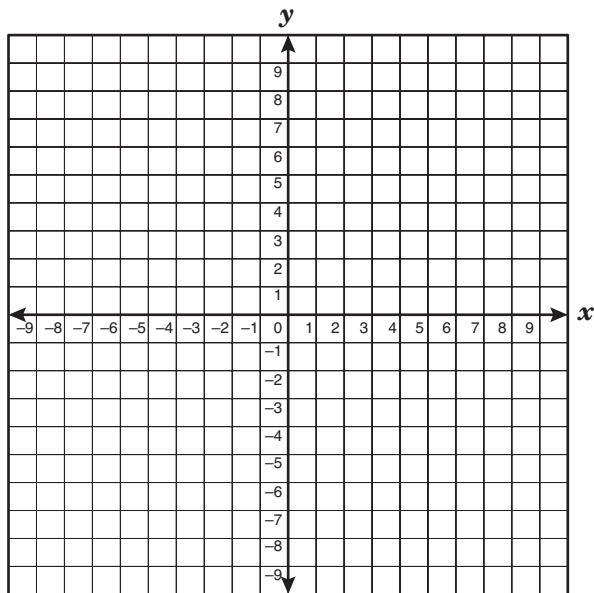

- A** (0, 3)
B (-1, 0)
C (1, 4)
D (3, 0)

44 Look at the solid sphere and the cylinder containing water shown in Figure 1.

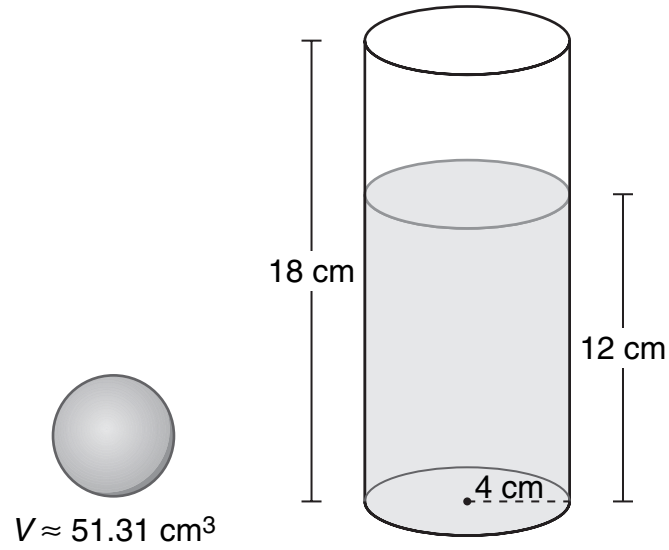

Figure 1

Figure 2 shows the sphere submerged in the water inside the cylinder.

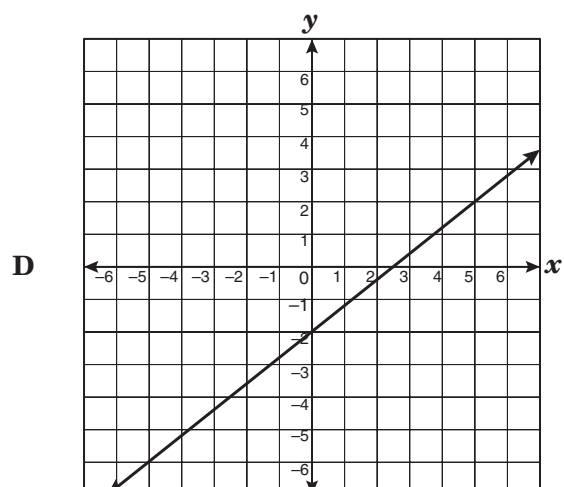
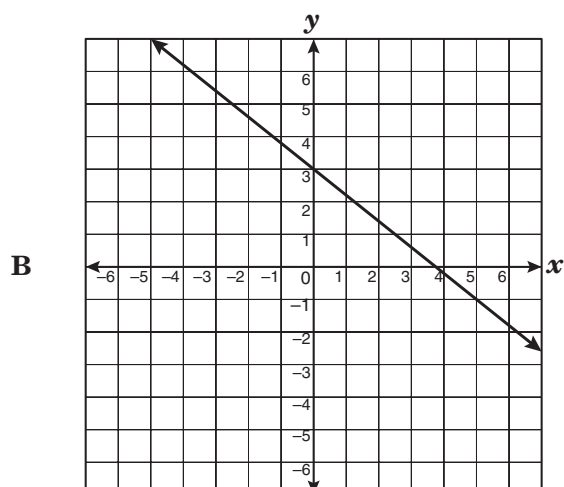
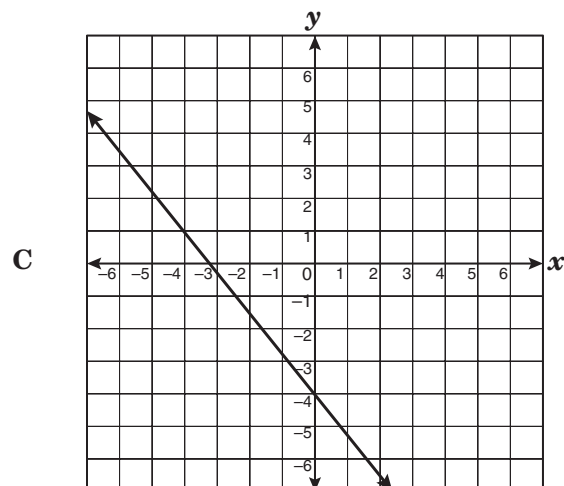
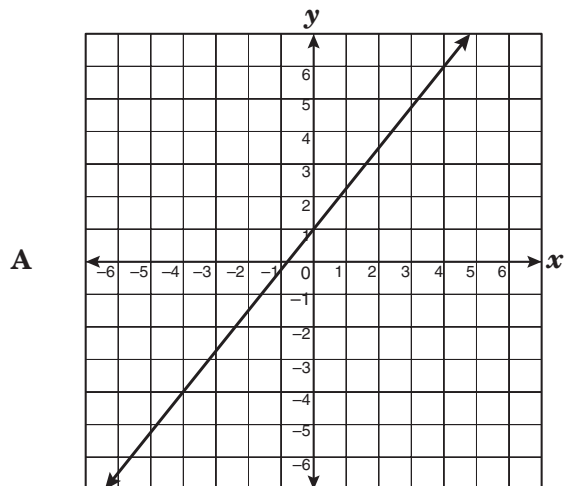

Figure 2

Which is closest to the height of the water level in Figure 2?

- F 13 cm
- G 17 cm
- H 15 cm
- J 11 cm

45 Which graph best represents a line that is parallel to the graph of the equation $y = -\frac{4}{5}x - 2$?



46 How does the graph of $y = -\frac{3}{4}x^2$ differ from the graph of $y = \frac{4}{3}x^2$?

F The graph of $y = -\frac{3}{4}x^2$ opens downward and is wider than the graph of $y = \frac{4}{3}x^2$.

G The graph of $y = -\frac{3}{4}x^2$ opens upward and is wider than the graph of $y = \frac{4}{3}x^2$.

H The graph of $y = -\frac{3}{4}x^2$ opens upward and is narrower than the graph of $y = \frac{4}{3}x^2$.

J The graph of $y = -\frac{3}{4}x^2$ opens downward and is narrower than the graph of $y = \frac{4}{3}x^2$.

47 Four square pieces are cut from the corners of a square sheet of metal. As the size of the small squares increases, the remaining area decreases, as shown below.

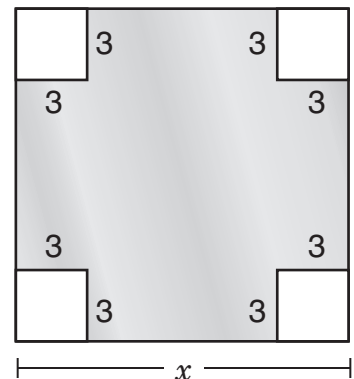
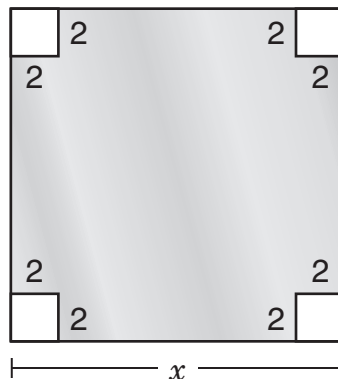
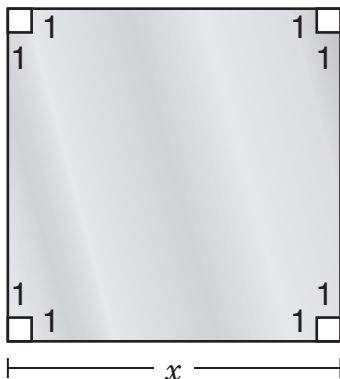

If this pattern continues, what will be the difference between the first square's shaded area and the fifth square's shaded area?

- A 4 square units
- B 24 square units
- C 49 square units
- D 96 square units

- 48 The graph below shows the amount of force needed to stretch a certain spring to various distances.

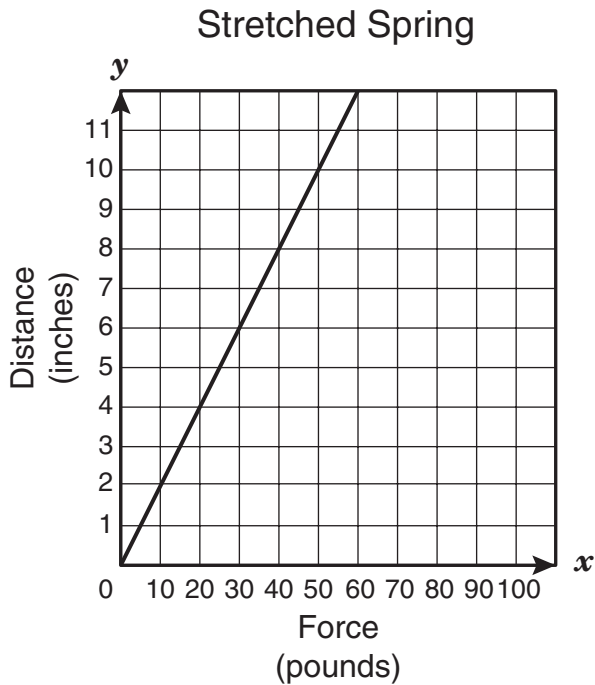

Which of the following best represents the difference between the amount of force in pounds needed to stretch the spring to 10 inches and the amount needed to stretch it to 4 inches?

- F 6
- G 14
- H 30
- J 70

- 49 Find the x - and y -intercepts of $-4x + 7y = -28$.

- A x -intercept: $(-4, 0)$
 y -intercept: $(0, 7)$
- B x -intercept: $(7, 0)$
 y -intercept: $(0, -4)$
- C x -intercept: $(0, 7)$
 y -intercept: $(-4, 0)$
- D x -intercept: $(0, -4)$
 y -intercept: $(7, 0)$

- 50 Four friends took turns using the stationary bike at a health club. Huan used it three times as long as Melanie. Susie used it half as long as David, and David used it 15 minutes longer than Huan. The four friends used the stationary bike for a total of 2.5 hours. How long did Susie use the stationary bike?

- F 60 min
- G 45 min
- H 30 min
- J 15 min

- 51 In the figures below, $\triangle HKM \sim \triangle RTV$, and the area of $\triangle HKM$ is equal to 10 square units.

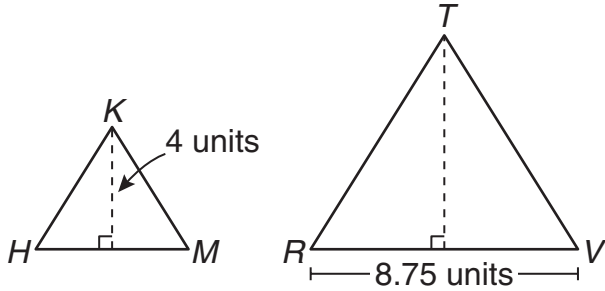

What is the area of $\triangle RTV$?

- A 30.625 square units
 B 87.5 square units
 C 21.875 square units
 D 61.25 square units
- 52 What is the rate of change of the function $y = -7$?
- F 7
 G -7
 H 0
 J Undefined

- 53 The manager of the Sherbet Shoppe wants to construct a circle graph showing the popularity of the various sherbet flavors he offers. Here is the tally of the favorite flavors of his first 30 customers on Saturday.

Favorite Sherbet Flavors

Pineapple	I
Lime	
Lemon	I
Raspberry	
Orange	

In the circle graph, which proportion can be used to find the number of degrees in the sector for orange sherbet?

- A $\frac{10}{20} = \frac{x}{180}$
 B $\frac{10}{30} = \frac{x}{180}$
 C $\frac{10}{20} = \frac{x}{360}$
 D $\frac{10}{30} = \frac{x}{360}$

54 Which graph best represents the relationship shown in the table below?

x	y
-1	-0.5
0	0
1	0.5
2	4

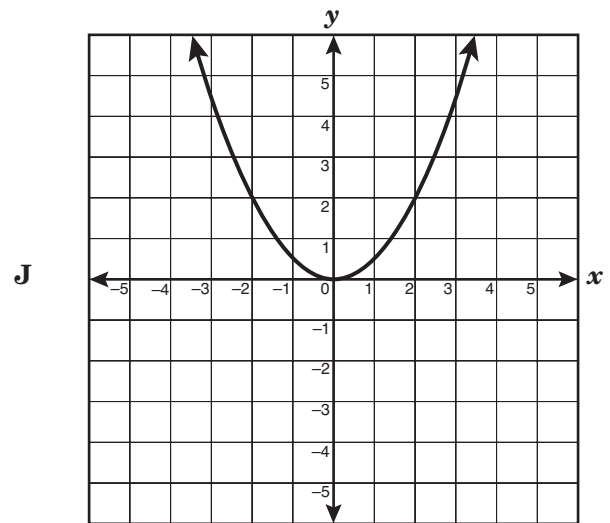
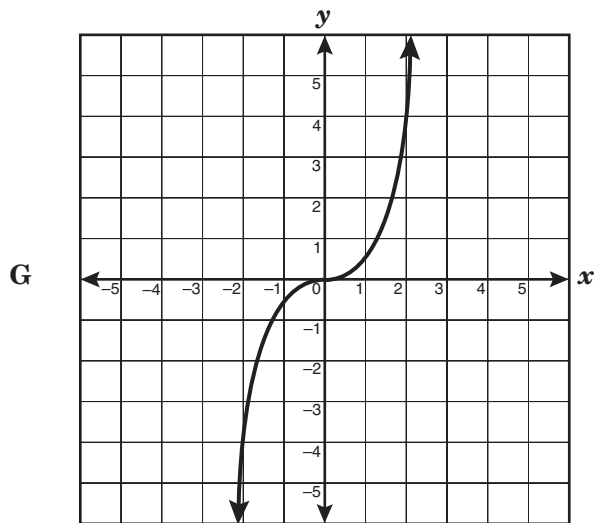
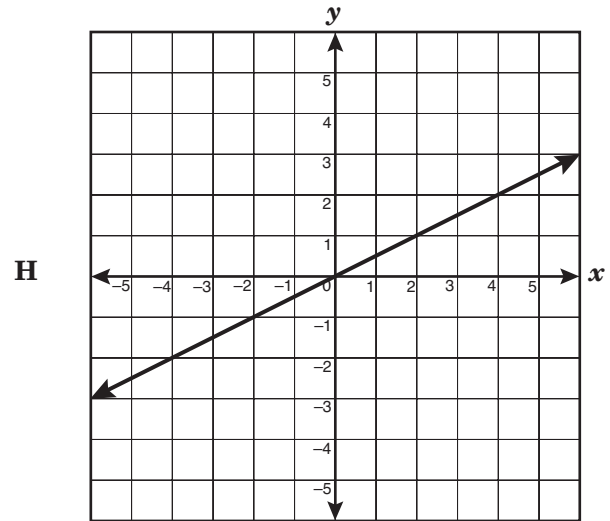
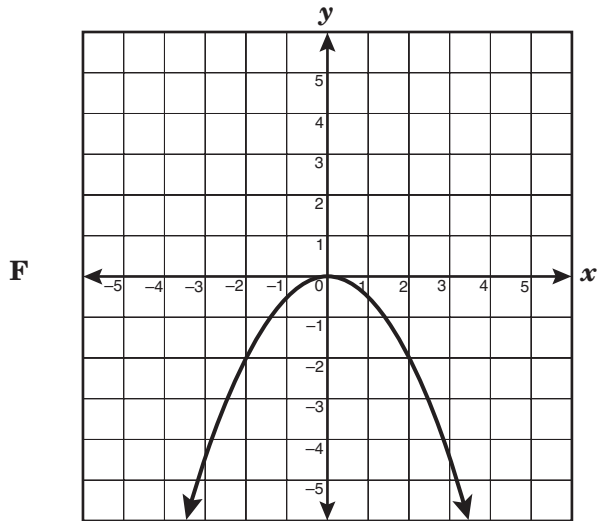

- 55 Lisa wants to make a long-distance telephone call to her friend. She does not want to spend more than \$5.00 on the telephone call. If there is a \$0.50 connection fee and a charge of \$0.11 per minute, which best represents the number of minutes that Lisa can talk to her friend?

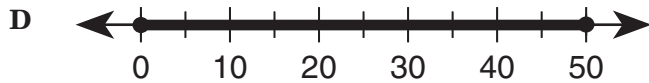
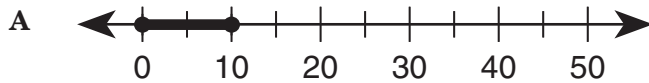

- 56 A sporting-goods store sold a total of 80 backpacks at the beginning of a new school year. Each backpack sold for either \$35 or \$50, not including tax. If x represents the number of \$35 backpacks the store sold, which expression represents the total amount of money in dollars from the sales of the two kinds of backpacks, not including tax?

- F $35x + 50(x - 80)$
G $50x + 35(80 - x)$
H $35x + 50(80 - x)$
J $50x + 35(x - 80)$

- 57 Which equation is the parent function of a quadratic equation?

- A $y = \sqrt{x}$
B $y = x$
C $y = |x|$
D $y = x^2$

- 58 The owners of Crispy Sweet Doughnut Shop want to open a shop centrally located to the police station, the high school, the fire station, and the factory.

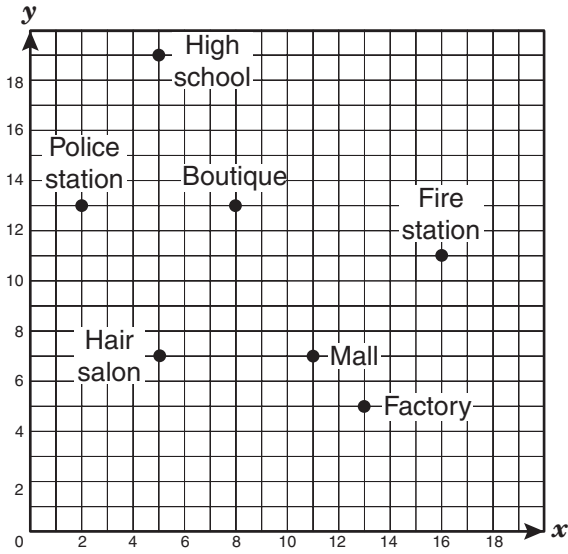

Based on the information given, which of the following points best represents the location where the new Crispy Sweet Doughnut Shop should open?

- F (9, 12)
- G (5, 13)
- H (6, 10)
- J (8, 13)

- 59 According to the data shown below, which would be the best prediction of the number of passengers at the International Jetport for the year 2008?

Passengers at International Jetport

Year	Number of Passengers (millions)
1980	30.6
1985	38.5
1990	46.4
1995	54.3
2000	62.2

- A 70.1 million
- B 68.5 million
- C 74.8 million
- D 78.0 million

60 The illustration below shows a 3-dimensional view of a screw.

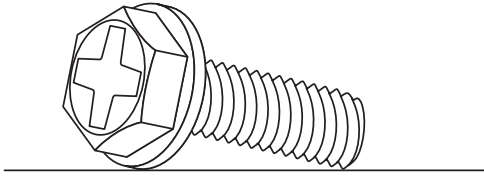

Which of the following best represents a front, a side, or a top view of this screw?

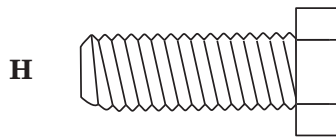
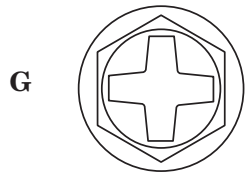
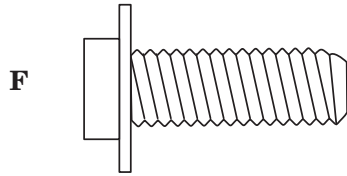

BE SURE YOU HAVE RECORDED ALL OF YOUR ANSWERS
ON THE ANSWER DOCUMENT.



